



MODEL MANUAL FOR SUPPLY VESSEL

BY

DET NORSKE VERITAS

This is an example of a Cargo Securing Manual according to “Guidelines for the Preparation of the Cargo Securing Manual” (IMO MSC/Circ.745) and the “Amendments to the Code of Safe Practice for Cargo Stowage and Securing (IMO MSC/Circ.1026)”.

Accelerations and securing is based on DNV’s IMO LASHCON™, hence it is assumed that the vessel have IMO LASHCON™ installed onboard.

The latest amendments as per the end of May 2002 are covered in this model manual.

Inquiries may be directed to:

Det Norske Veritas
MTPNO876 Bulk & Container Ships
Veritasveien 1
N-1322 HØVIK, NORWAY

Telephone: + 47 67 57 99 00
Fax: + 47 67 57 99 11

Version: 1
Date: 04-01-01

**Cargo Securing Manual
for
M/S TEST VESSEL**

1 Contents

1	Contents	3
2	General.....	4
2.1	Ship Data.....	4
2.2	Definitions	5
2.3	General Information.....	5
2.4	Principal sources of danger	6
3	Securing Devices and Arrangements.....	7
3.1	Specification of Fixed Cargo Securing Devices.	7
3.2	Specification of Portable Cargo Securing Devices.	7
3.3	Inspection and Maintenance Schemes	8
4	Stowage and Securing of cargo	11
4.1	Handling and safety instructions.....	11
4.1.1	General principles of cargo securing.....	11
4.1.2	Safe handling of cargo securing devices	12
4.1.3	Evaluation of forces acting on cargo units	12
4.1.4	Forces acting on typical cargo units	14
4.1.5	Calculation of forces in semi- and non-standardised lashing arrangements.....	15
4.1.5.1	MSLs for different securing devices	15
4.1.5.2	Safety factor	15
4.1.5.3	Simplified method – Rule of thumb	15
4.1.5.4	Specific Example based on Alternative Method – using IMO LASHCON™	16
4.1.5.5	Ship Specific example – using IMO LASHCON™	19
4.2	Application of portable securing devices.....	20
	Appendix I – Log for maintenance of cargo securing equipment.....	21
	Appendix II – Manual procedure for calculation of lashings.....	23
	Appendix III – Applicable Annexes from the CSS Code.....	34
ANNEX 1	Safe stowage and securing of containers on deck of ships which are not specially designed and fitted for the purpose of carrying containers.....	34
ANNEX 2	Safe stowage and securing of portable tanks.	36
ANNEX 3	Safe stowage and securing of portable receptacles.	38
ANNEX 4	Safe stowage and securing of wheel-based (rolling) cargoes	40
ANNEX 5	Safe stowage and securing of heavy cargo items such as locomotives, transformers, etc.	41
ANNEX 7	Safe stowage and securing of heavy metal products.....	44
ANNEX 8	Safe stowage and securing of anchor chains.....	45
ANNEX 12	Safe stowing and securing of unit loads.....	46
	Appendix IV – LASHCON™ IMO USER GUIDE	49
1	General.....	50
1.1	Introduction.....	50
1.2	System requirements	50
1.3	User requirements	50
2.	User guide.....	51
2.1	Input sequence.....	51
2.2	Input data.....	53
2.3	Calculation methods.....	55
2.4	Special features of Lashcon IMO	55
2.5	Program assumptions	55
	Appendix V – Certification for fixed cargo securing devices	57
	Appendix VI – Certification for portable cargo securing devices.....	57

2 General

2.1 Ship Data

General Data

Ship Name:	M/S Test Vessel
DNV Id No:	12345
IMO No:	67890123
Flag	Flag
Class Notation	⊕1A1 Supply Vessel

Ship dimensions

Length, Lpp	90,5 m
Beam, B	11.0 m
Depth moulded, D	9,5 m
Draft, T	5,0 m
Speed, V	14,5 kn
GM, range of values	0.5 - 2.5 m

Reference documents

Document/Manual	Issue date	Approval date
Loading Manual	03.12.21	04.01.01
Trim & Stability Booklet	03.12.21	04.01.01

2.2 Definitions

“Cargo Securing Devices” is all fixed and portable devices used to secure and support cargo units.

“Maximum Securing Load” (MSL) is a term used to define the allowable load capacity for a device used to secure cargo to a ship. “Safe Working Load” (SWL) may be substituted for MSL for securing purposes, provided this is equal to or exceeds the strength defined by MSL.

“Standardized Cargo” means cargo for which the ship is provided with an approved securing system based upon cargo units of specific types.

“Semi-standardized Cargo” means cargo for which the ship is provided with a securing system capable of accommodating a limited variety of cargo units, such as vehicles, trailers, etc.

“Non-standardized Cargo” means cargo which requires individual stowage and securing arrangements.

“Cargo transport unit” means a road freight vehicle, a railway freight wagon, a freight container, a road tank vehicle, a railway tank wagon or a portable tank.

“Fixed Securing Devices” means securing points and supports either integral, i.e. welded into the hull structure, or non-integral, i.e. welded onto the hull structure.

“Portable Securing Devices” means portable devices used for lashing, securing or support of cargo units.

2.3 General Information

- 1 The guidance given herein should by no means rule out the principles of good seamanship, neither can they replace experience in stowage and securing practice.
- 2 The information and requirements set forth in this Manual are consistent with the requirements of the vessel's trim and stability booklet, International Load Line Certificate (1966), the hull strength loading manual (if provided) and with the requirements of the International Maritime Dangerous Goods (IMDG) Code (if applicable).
- 3 This Cargo Securing Manual specifies arrangements and cargo securing devices provided on board the ship for the correct application to and the securing of cargo units, containers, vehicles and other entities, based on transverse, longitudinal and vertical forces which may arise during adverse weather and sea conditions.
- 4 It is imperative to the safety of the ship and the protection of the cargo and personnel that the securing of the cargo is carried out properly and that only appropriate securing points or fittings should be used for cargo securing.
- 5 The cargo securing devices mentioned in this manual should be applied so as to be suitable and adapted to the quantity, type of packaging, and physical properties of the cargo to be carried. When new or alternative types of cargo securing devices are introduced, the Cargo Securing Manual should be revised accordingly. Alternative cargo securing devices introduced should not have less strength than the equipment which it replaces.
- 6 There should be a sufficient quantity of reserve cargo securing devices on board the ship.

- 7 Information on the strength and instructions for the use and maintenance of each specific type of cargo securing device, where applicable, is provided in this manual. The cargo securing devices should be maintained in a satisfactory condition. Items worn or damaged to such an extent that their quality is impaired should be replaced.

2.4 Principal sources of danger

Some important sources of danger:

1. Cargo badly stowed or inadequately secured inside or on cargo units.
2. Free surface effects in tank vehicles, tank containers or other bulk units which are slack.
4. Poorly maintained or inadequately illuminated decks.
5. Wet decks.
6. Failure to apply brakes correctly.
7. Insufficient or incorrectly applied lashings or the use of lashing equipment of the wrong type or of inadequate strength with respect to mass and centre of gravity of the cargo unit and the weather conditions likely to be encountered during the voyage.

3 Securing Devices and Arrangements

When securing devices are replaced, the inventory lists should, as far as practicable, be updated and relevant certificates inserted in an appropriate place in the manual.

3.1 Specification of Fixed Cargo Securing Devices.

No other attachments to the ship hull structure than those listed below shall be made without the Masters special permission.

Any lashing arrangements imposing loads exceeding the maximum securing loads listed in the inventory list may cause serious structural damage.

Fixed securing devices:

Type	Manufacturer	Type designation	Quantity	MSL [kN]	Sketch
Mounting hole in deck for support stanchions	Yard	-	14	98.1	Not included in this Model Manual
Portable eyelet for mounting hole in deck	Yard	-	14	98.1	Not included in this Model Manual
Support stanchions	Yard	-	8	NA	Not included in this Model Manual

3.2 Specification of Portable Cargo Securing Devices.

As a general rule-of-thumb, if doubt about determining the MSL, portable equipment should not be subject to loads exceeding what have been customary usage in the past.

Portable securing devices:

Type	Manufacturer	Type designation	Quantity	MSL [kN]	Sketch
Wire	“All wired up”	6x36 IWRC	2 x 60 m	252	Not included in this Model Manual
Load Binders	“The Load Binders”	-	5	127.5	Not included in this Model Manual
Snatch Block	“Blocks and Stuff”	-	2 x 12” 2 x 6”	78.5	Not included in this Model Manual
Lashing Chain	“Chain Chain”	B14804	10 m	78.5	Not included in this Model Manual

3.3 Inspection and Maintenance Schemes

Regular inspections and maintenance are carried out under the responsibility of the Master.

Cargo securing device inspections should as a minimum include:

1. Routine visual examinations of components being utilised:
 - Before using any cargo securing device, whether fixed or portable, the equipment must be visually inspected to ensure that there are no defects and that when appropriate, all moving parts have been greased and are operating correctly.
 - After use, and before going into storage, each device should be visually inspected to ensure that the device has not sustained damage, is still in good condition and does not require repair or replacement. Especially after heavy weather voyages the lashing equipment should be carefully examined. Defective portable lashing equipment should be put aside into a suitable separate location, i.e. bins marked "BAD", and any necessary repairs and testing must be carried out prior to re-use. If beyond repair the equipment is to be scrapped.
 - Discarded parts of equipment should be replaced by equivalent parts. Cargo Securing Equipment is only to be renewed by certified equipment.
 - All portable securing devices shall be visually examined and greased as necessary at intervals not exceeding 3 months.
 - Portable equipment not in use should be collected and stored in bins.
2. Periodic examinations/re-testing as required by the Administration. When required, the cargo securing devices concerned should be subjected to inspections by DNV.
 - The welds connecting the fixed cargo securing equipment to the ship's structure should be inspected regularly and any fractures or tearing should be gouged out and rewelded. Welding of the device to the structure should be carried out by approved personnel in accordance with recognised welding practice.
 - If the underlying structure of the deck, tank top, hatch covers, bulkheads or side structure is deformed to such an extent that an uneven stow would result, the structure should be repaired by the most appropriate method. Any significant deformation of the ship's structure in way of securing points is to be reported to DNV at the earliest opportunity.
 - Cargo securing equipment used several times, both loose and fixed, should be re-tested regularly. The equipment to be tested should be selected by random selection, for instance 1 of 50 pieces of each type of equipment. These tests should be to proof strength load.

CARGO SECURING MANUAL FOR M/S TEST VESSEL

The following procedures should be followed for accepting, maintaining, repairing or rejecting cargo securing devices, and should be carried out by the ship's crew:

Cargo Sec. Device	Inspection Check if/for:	Maintenance	Actions To be:
Elephantfoot pots	deformed		repaired or replaced
	corroded		replaced if top plate is less than 75 % of original
Turnbuckle	bent	* see below	straightened
	pins damaged or missing		renewed
	hook damaged		renewed
	destructive, thread		scrapped
Lashing chain w/tensioner	link is deformed		replace if any link is deformed
Wire rope lashings	permanent kinks flattening corrosion drying out of the fibre core protrusion of the fibre core		replaced if any of the listed defects are found
Shackles	bolt damaged or missing		renewed
	bent		scrapped
	wear and tear		scrapped
Twistlock	handle damaged/missing	* see below	straightened/renewed
	spring/ball/bolts and nuts damaged		renewed
	amount of small cracks		scrapped
Bridgefitting	nuts damaged or missing	* see below	renewed
	bent		straightened
	destructive; thread		scrapped

* Threads of turnbuckles, twistlocks and bridgefittings should be greased regularly, at least every 3 months.

Inspections and adjustments of securing arrangements during the voyage:

1. The securing devices should be regularly inspected to ensure that the cargo remains safely secured throughout the voyage.
2. The securing arrangement should be adjusted, if found necessary after inspection, during the voyage. Adjustment of securing devices include re-tightening of lashings or remaking the lashing. If necessary additional lashings should be fitted, and if possible the friction could be increased. This is particular important when heavy weather or swell is expected. Moreover, when heavy weather has passed.

Particular attention should also be paid to lashings which may become slack due to the cargo deforming or compacting during the voyage. Lashings may also become slack when cargoes are loaded and secured in conditions of low ambient temperature and the vessel then proceeds to areas of significantly higher ambient temperature.

3. If adjustment to the cargo securing arrangement has to be carried out at sea under adverse weather and sea conditions adequate precautions have to be taken to avoid dangerous situations for the crew. Good seamanship is necessary.
4. During a voyage, partial discharge may result in an exposed cargo face. This should preferably be secured while loading to avoid hazards while discharging other cargo.

CARGO SECURING MANUAL FOR M/S TEST VESSEL

5. Sufficient reserve securing devices should be carried to deal with unexpected circumstances.
6. Entries of all examinations and adjustments to lashings should be made in the ship's record book.

Inspections and maintenance carried out are to be entered into the "Log for Maintenance of Cargo Securing Equipment", see Appendix I.

4 Stowage and Securing of cargo

4.1 Handling and safety instructions

4.1.1 General principles of cargo securing

1. Cargo shall be secured according to recognised principles, taking into account the dynamic forces that may occur during sea transport and the most severe weather condition expected. Ship handling decisions should take into account the type of cargo and stowage position of the cargo and the securing arrangements.
 - Care should be taken to distribute the forces as evenly as possible.
 - If in doubt the lashing arrangement should be verified using an acceptable calculation method.
 - The securing gear should be adapted to the cargo to be carried.
 - Lashings are to be kept as short as possible.

2. Prior to loading cargo, the following should be checked:
 - Relevant deck areas are, as far as practicable, to be clean, dry and free from oil and grease.
 - Cargo, cargo transport unit or vehicle to be suitable for transport.
 - Necessary securing equipment is to be found onboard.
 - See item 5.

3. The securing equipment should be:
 - available in sufficient quantity including reserves
 - suitable for the purpose**
 - of adequate strength*
 - practical and maintained**

* The required strength, which depends on the lashing forces, can be calculated based on methods for evaluating forces as outlined in this manual.

** Specific handling and safety instructions are provided in sub-chapter 4.1.2 along with instructions to suitable areas, while the maintenance are dealt with in chapter 3.3.

4. Securing operations shall be completed before the ship leaves the berth and the securing should be based on proper planning, execution and supervision. Relevant personnel should be properly qualified and experienced and should have a sound practical knowledge of the application and content of this Cargo Securing Manual.
 - The master shall take care in planning and supervising the stowage and securing of cargoes based on information about the cargo.
 - The cargo is to be distributed with attention to the ship stability so that the hazards of excessive accelerations are reduced as far as practicable.
 - Due attention to the ship's structural strength should be taken.

Excessive accelerations are expected to occur in the far forward and aft part of the ship, but can also occur in general as a result of a high GM value.

5. Where practicable, cargo units shall be provided with a Cargo Stowage and Securing Declaration, stating that the cargo has been properly stowed and secured, taking into account the

IMO/ILO Guidelines for Packing Cargo in Freight Containers or Vehicles. In general, cargo carried in containers, road vehicles, ship borne barges, railway wagons and other transport units should be properly packed and secured within these units. Relevant expertise should be called for, if found necessary, when considering the shipment of a cargo with unusual characteristics, i.e. cargo which may require special attention to location, stowage/securing and weather conditions.

- Different commodities should be compatible with each other or suitable separated
 - Cargo must be suitable for the ship and vice versa
6. If the duty officer considers that a cargo is not safely secured to a cargo unit, measures shall be taken to avoid shifting of the cargo. If adequate measures are not possible, due to the nature of the cargo or lack of securing points, the cargo unit shall not be taken on board. Reference in this respect is made to TFK Report 1990:6E “Loading and Securing Cargo on Load Carriers, Advice and instructions”.
 7. The securing arrangements shall be adequate to ensure that there will be no movement which will endanger the ship. Slackening of the securing gear due to cargoes which have a tendency to deform or to compact during voyage shall be avoided. Cargoes with low friction coefficient should also be tightly stowed across the ship to avoid sliding. Suitable material such as soft boards or dunnage should be used to increase friction, ref. paragraph 7.2.1 of the CSS Code.
 8. Cargo units containing hanging loads (e.g. chilled meat, floated glass) and very high cargo units are, because of the relatively high position of the centre of gravity, particularly prone to tipping. Whenever possible they should be located in positions of least movement i.e. on the centre line, towards amidships and on a deck near the waterline.
 9. Safe means of access to securing arrangements, safety equipment, and operational controls shall be provided and properly maintained. Stairways and escape routes from spaces below the vehicle deck shall be kept clear. The cargo spaces should be, as far as practicable, regularly inspected during voyage.
 10. Lashings shall not be released for unloading before the ship is secured at the berth, without the Masters express permission.
 11. Cargo shall not obstruct the operating controls of stern doors, entrances to accommodation and/or fire fighting equipment.
 12. Dangerous goods shall be segregated, stowed and secured according to the IMDG code and valid instructions for this ship.

4.1.2 Safe handling of cargo securing devices

This subchapter should contain clear and specific handling and safety instructions for all the cargo securing devices used on board. The instructions should be based on the manufacturer’s guidance literature. In order to be effective and simple to use, the instructions should be visualized by means of sketches, figures or photos.

4.1.3 Evaluation of forces acting on cargo units

Lashing forces are derived from accelerations of the cargo due to ship motions. The largest accelerations, and therefore the most severe forces, can be expected in the furthest forward, the furthest aft and the highest stowage positions on each side of the ship. Special consideration should be given to the securing of vehicles stowed in these positions. Generally the forces which have to be

taken by the securing devices are composed of components acting relative to the axes of the ship, i.e. longitudinal, transverse and vertical direction. The two first are the most important to consider with respect to lashing since the main function of lashings are to prevent cargo units from tipping and/or sliding, in the transverse or longitudinal direction.

The transverse accelerations increase directly with the GM value, and care should be taken when stowing and distributing cargo to avoid excessive accelerations, ref. sub-chapter 4.1.1 “General principles of cargo securing”.

If cargo is stowed in positions where loads from wind pressure and/or sea sloshing may be expected, this shall be taken into consideration when securing the cargo.

Due to uncertainties as to the actual weights and locations of the centre of gravity of cargo units, the lashing forces may vary considerably. It is not possible to specify exactly the maximum forces which may be exerted in the most severe conditions. A general rule is that an adequate number of lashings of sufficient strength to meet the worst weather that could be encountered during the voyage should always be fitted. If very heavy weather is expected, appropriate operational measures, such as delaying sailing or altering course or speed, should be taken to minimise the forces.

Due to the difficulty in predicting dynamic accelerations and the complexity of dynamic calculations, the lashing forces apply to rigid and unsprung cargo. Additional lashings will be required to resist dynamic forces due to sprung or non-rigid cargoes.

The lashings are in general most effective on a cargo unit when they make an angle with the deck of between 30° and 60°. When these optimum angles cannot be achieved, additional lashings may be required.

The forces can be estimated based on the calculation methods outlined in this Cargo Securing Manual. The effect of anti roll devices should not be taken into account when planning the stowage and securing of cargoes.

4.1.4 Forces acting on typical cargo units

Cargo units/cargo transport units on a ship will in principles be subjected to the forces given on the drawing below.

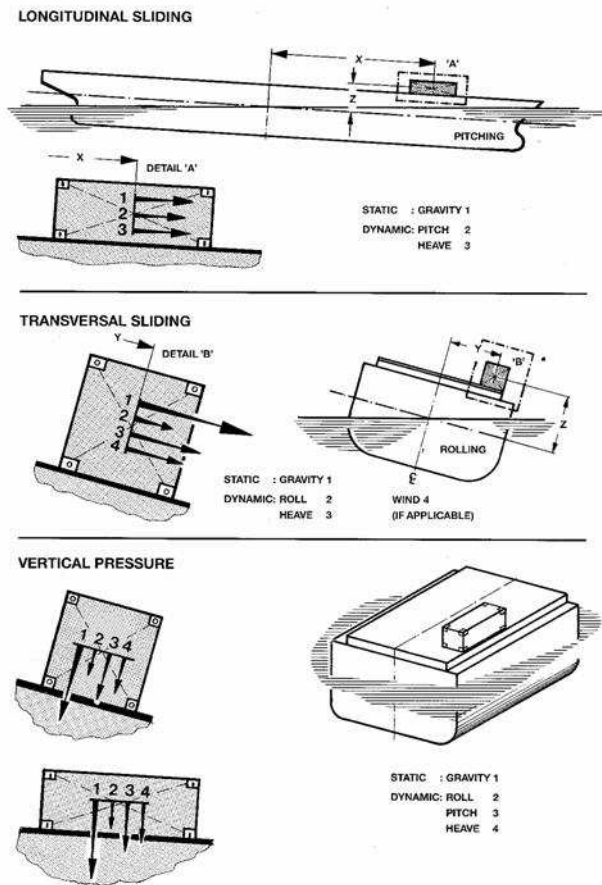

Source: Mac Gregor Conner

4.1.5 Calculation of forces in semi- and non-standardised lashing arrangements

We have used IMO LASHCON™ for all the calculations in the Cargo Securing Manual for M/S Test Vessel, and M/S Test Vessel have also IMO LASHCON™ installed onboard. As an alternative to use IMO LASHCON™, a calculation procedure based on Annex 13 to the CSS Code and Amendments to the Code of Safe Practice for Cargo Stowage and Securing (IMO MSC/Circ.1026) is included in Appendix II.

4.1.5.1 MSLs for different securing devices

MSLs for different securing devices are given in table 1 if not given else where.

The MSL of timber should be taken as 0.3 kN/cm² normal to the grain.

Material	MSL
Shackles, deckeyes, twistlocks, lashing rods, D-rings, stackers, bridge fittings, turnbuckles of mild steel	50% of breaking strength
Fibre rope	33% of breaking strength
Wire rope (single use)	80% of breaking strength
Wire rope (re-useable)	30% of breaking strength
Steel band (single use)	70% of breaking strength
Chains	50% of breaking strength
Web lashings	50% of breaking strength

Table 1 - Determination of MSL from breaking strength

For particular securing devices (e.g. fibre straps with tensioners or special equipment for securing containers), a permissible working load may be prescribed and marked by authority. This should be taken as the MSL.

When the components of a lashing device are connected in series (for example, a wire to a shackle to a deckeye), the minimum MSL in the series shall apply to that device.

4.1.5.2 Safety factor

When using balance calculation methods for assessing the strength of the securing devices, a safety factor is used to take account of the possibility of uneven distribution of forces among the devices or reduced capability due to the improper assembly of the devices or other reasons. This safety factor is used in the formula to derive the calculated strength (CS) from the MSL and shown in the relevant method used.

$$CS = MSL/safety\ factor$$

Notwithstanding the introduction of such a safety factor, care should be taken to use securing elements of similar material and length in order to provide a uniform elastic behaviour within the arrangement.

4.1.5.3 Simplified method – Rule of thumb

The total of the MSL values of the securing devices on each side of a unit of cargo (port as well as starboard) should equal the weight of the unit. (The weight of the unit should be taken in kN).

This method, which implies a transverse acceleration of 1g (9.81 m/s²), applies to nearly any size of ship, regardless of the location of stowage, stability and loading condition, season and area of operation. The method, however, takes into account neither the adverse effects of lashing angles and non-homogeneous distribution of forces among the securing devices nor the favourable effect friction.

Transverse lashing angles to the deck should not be greater than 60° and it is important that adequate friction is provided by the use of suitable material. Additional lashings at angles of greater than 60° may be desirable to prevent tipping but are not to be counted in the number of lashings under the rule-of-thumb.

4.1.5.4 Specific Example based on Alternative Method – using IMO LASCHON™

Input to IMO LASCHON™:

Lpp = 90.5 m
 B = 11.0 m
 Speed = 14.5 kn
 GM = 2.5 m

Cargo mass: 15 t
 Dimensions: L = 3.4 m, B = 1.0 m, H = 1.2 m
 Stowage: 0.7 L on deck low.
 MSL of lashings: 60 kN
 μ: 0.3 (steel – timber)

Lever arm of tipping: a = 0.6 m
 Lever arm of stability: b = 0.5 m
 Horizontal distance from securing to tipping axis: d = 1.15 m

Force by wind pressure:

Longitudinal direction = $F_W = 3.4 \text{ m} \times 1.2 \text{ m} \times 1 \text{ kN/m}^2 = 4.1 \text{ kN}$
 Transverse direction = $F_W = 1 \times 1.2 = 1.2 \text{ kN}$

Force by sea pressure:

Longitudinal direction = $F_S = 3.4 \times 1.2 = 4.1 \text{ kN}$
 Transverse direction = $F_S = 1 \times 1.2 = 1.2 \text{ kN}$



CARGO SECURING MANUAL FOR M/S TEST VESSEL

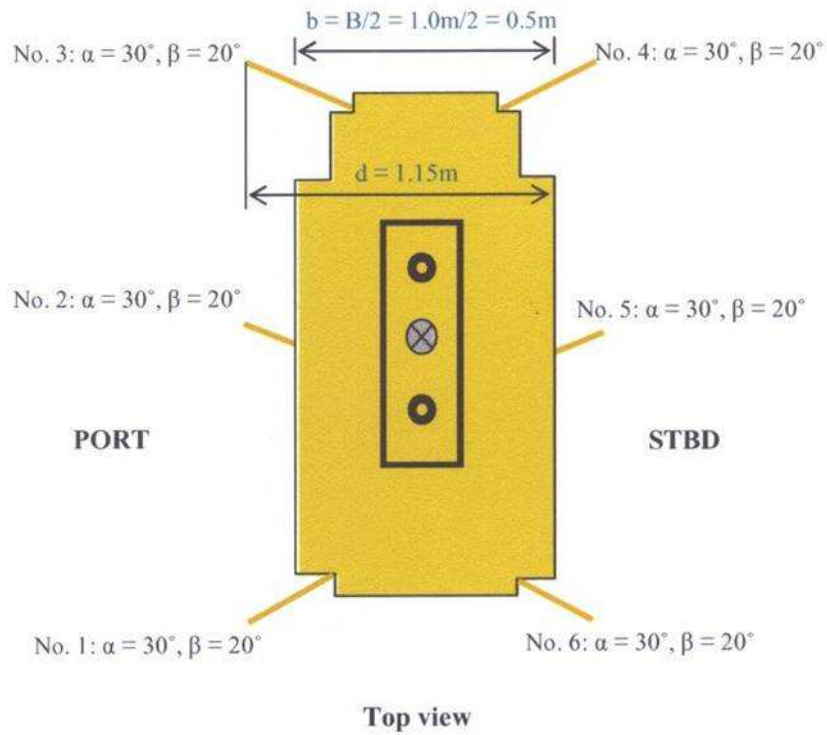

Print outs from IMO LASHCON™:

	Code of Safe Practice for Cargo Stowage and Securing 2003 Edition, Annex 13			LASHCON IMO Version 9.0 December 2003		Sign: _____ Time: 14:07 Date: 04.02.12
	<p>About LASHCON™: LASHCON is a MS EXCEL based calculation tool for control of lashing-arrangements for semi- and non-standardised cargo. The program is developed by Det Norske Veritas, and is based on the calculation procedures outlined in Annex 13 to the Code of Safe Practice for Cargo Stowage and Securing, 2003 Edition.</p> <p>Program assumptions: Reference is made to the User Manual.</p>					
Input of main vessel data:						
Vessel Name:	Ship Id:	Lpp [m]:	B [m]:	V [kn]:	GM [m]:	
M/S Test Vessel		90,5	11,0	14,5	2,5	
<p>NOTES:</p> <p>Note! B/GM < 7 Accelerations are extrapolated outside the range given in Annex 13.</p>						

CARGO SECURING MANUAL FOR M/S TEST VESSEL

	Code of Safe Practice for Cargo Stowage and Securing 2003 Edition, Annex 13		LASHCON IMO Version 9.0 December 2003				Sign: Time: 14:07 Date: 04.02.12																																																																																		
	Input of cargo unit data Cargo unit specification: Mass of cargo unit: Coefficient of friction: Wind exposed area: Sea exposed area: Lever arm of tipping: Lever arm of stability:			Generator m 15,00 ton μ 0,30 (-) Transv. Long Aw 1,20 4,10 m ² As 1,20 4,10 m ² a 0,60 m b 0,50 m		Give cargo unit stowage position Vertical: Deck, low Longitudinal: 0.7 L Calculation method: <input checked="" type="radio"/> Alternative calculation Recommended <input type="radio"/> Advanced calculation																																																																																			
Input of lashing data Max securing load [kN]: Transverse lashing direction: Longitudinal lashing direction: Vertical securing angle [degr]: Vertical securing angle [degr]: Horizont. securing point distance:			<table border="1"> <tr> <td></td> <td>1</td><td>2</td><td>3</td><td>4</td><td>5</td><td>6</td><td>7</td><td>8</td><td>9</td><td>10</td> </tr> <tr> <td>MSL</td> <td>60</td><td>60</td><td>60</td><td>60</td><td>60</td><td>60</td><td></td><td></td><td></td><td></td> </tr> <tr> <td>Transverse lashing direction</td> <td>PS</td><td>PS</td><td>PS</td><td>SB</td><td>SB</td><td>SB</td><td></td><td></td><td></td><td></td> </tr> <tr> <td>Longitudinal lashing direction</td> <td>Aft</td><td>Fwd</td><td>Fwd</td><td>Fwd</td><td>Fwd</td><td>Aft</td><td></td><td></td><td></td><td></td> </tr> <tr> <td>Vertical securing angle [degr]: α</td> <td>30</td><td>30</td><td>30</td><td>30</td><td>30</td><td>30</td><td></td><td></td><td></td><td></td> </tr> <tr> <td>Vertical securing angle [degr]: β</td> <td>20</td><td>20</td><td>20</td><td>20</td><td>20</td><td>20</td><td></td><td></td><td></td><td></td> </tr> <tr> <td>Horizont. securing point distance: d [m]</td> <td>1,2</td><td>1,2</td><td>1,2</td><td>1,2</td><td>1,2</td><td>1,2</td><td></td><td></td><td></td><td></td> </tr> </table>											1	2	3	4	5	6	7	8	9	10	MSL	60	60	60	60	60	60					Transverse lashing direction	PS	PS	PS	SB	SB	SB					Longitudinal lashing direction	Aft	Fwd	Fwd	Fwd	Fwd	Aft					Vertical securing angle [degr]: α	30	30	30	30	30	30					Vertical securing angle [degr]: β	20	20	20	20	20	20					Horizont. securing point distance: d [m]	1,2	1,2	1,2	1,2	1,2	1,2				
	1	2	3	4	5	6	7	8	9	10																																																																															
MSL	60	60	60	60	60	60																																																																																			
Transverse lashing direction	PS	PS	PS	SB	SB	SB																																																																																			
Longitudinal lashing direction	Aft	Fwd	Fwd	Fwd	Fwd	Aft																																																																																			
Vertical securing angle [degr]: α	30	30	30	30	30	30																																																																																			
Vertical securing angle [degr]: β	20	20	20	20	20	20																																																																																			
Horizont. securing point distance: d [m]	1,2	1,2	1,2	1,2	1,2	1,2																																																																																			
RESULTS: Actual forces Transverse sliding force [kN]: 183,8 Longitudinal sliding force [kN]: 53,7 Cargo tipping moment [kNm]: 110,3			Securing capacity [kN / kNm] Transv. capacity: PS [kN] 173 Not OK SB [kN] 173 Not OK Long. capacity: Fwd [kN] 94 OK Aft [kN] 55 OK Tipping capacity: PS [kN] 146 OK SB [kN] 146 OK				Accelerations Transverse: a _t = 12,09 m/s ² Vertical: a _v = 6,49 m/s ² Longitudinal: a _l = 3,04 m/s ²																																																																																		
Note! B/GM < 7 Accelerations are extrapolated outside the range given in Annex 13																																																																																									
Main Vessel Data																																																																																									

Conclusion:

One extra lashing in both port and starboard direction is needed

CARGO SECURING MANUAL FOR M/S TEST VESSEL

4.1.5.5 Ship Specific example – using IMO LASHCON™

Print out of accelerations for GM = 0.5, GM = 1.5 and GM = 2.5:

Vessel Name: M/S Test Vessel		Ship Id:										
Accelerations according to Annex 13 to IMO Res. A714(17)												
Long. position:	Transverse acceleration a_y in m/s^2											Long acc a_x in m/s^2
	0,0	0,1	0,2	0,3	0,4	0,5	0,6	0,7	0,8	0,9	1,0	
Deck, high	7,75	7,43	7,22	7,12	7,02	7,02	7,12	7,22	7,43	7,75	8,17	3,98
Deck, low	7,02	6,81	6,60	6,39	6,39	6,39	6,39	6,60	6,81	7,02	7,33	3,04
Tween-deck	6,49	6,18	5,86	5,76	5,65	5,65	5,76	5,86	6,18	6,49	6,91	2,09
Lower hold	6,18	5,76	5,55	5,34	5,24	5,24	5,34	5,55	5,76	6,18	6,60	1,57
	Vertical acceleration a_z in m/s^2											
	9,63	7,96	6,49	5,24	4,50	4,50	5,24	6,49	7,96	9,63	11,52	

Note !
These accelerations
apply only
for GM=0,50m

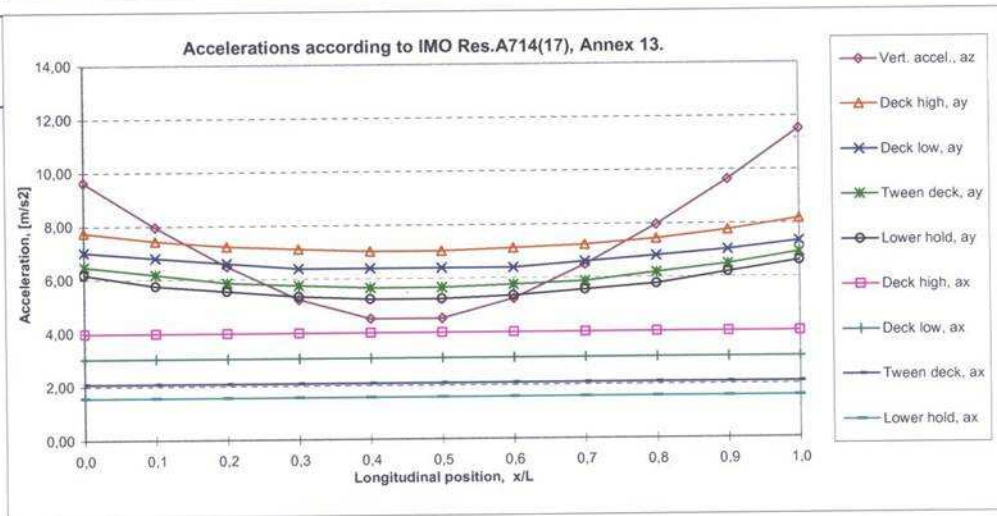

Vessel Name: M/S Test Vessel		Ship Id:										
Accelerations according to Annex 13 to IMO Res. A714(17)												
Long. position:	Transverse acceleration a_y in m/s^2											Long acc a_x in m/s^2
	0,0	0,1	0,2	0,3	0,4	0,5	0,6	0,7	0,8	0,9	1,0	
Deck, high	11,67	11,20	10,88	10,73	10,57	10,57	10,73	10,88	11,20	11,67	12,30	3,98
Deck, low	9,68	9,39	9,10	8,81	8,81	8,81	8,81	9,10	9,39	9,68	10,11	3,04
Tween-deck	8,03	7,64	7,25	7,12	6,99	6,99	7,12	7,25	7,64	8,03	8,55	2,09
Lower hold	7,04	6,56	6,33	6,09	5,97	5,97	6,09	6,33	6,56	7,04	7,52	1,57
	Vertical acceleration a_z in m/s^2											
	9,63	7,96	6,49	5,24	4,50	4,50	5,24	6,49	7,96	9,63	11,52	

Note !
These accelerations
apply only
for GM=1,50m

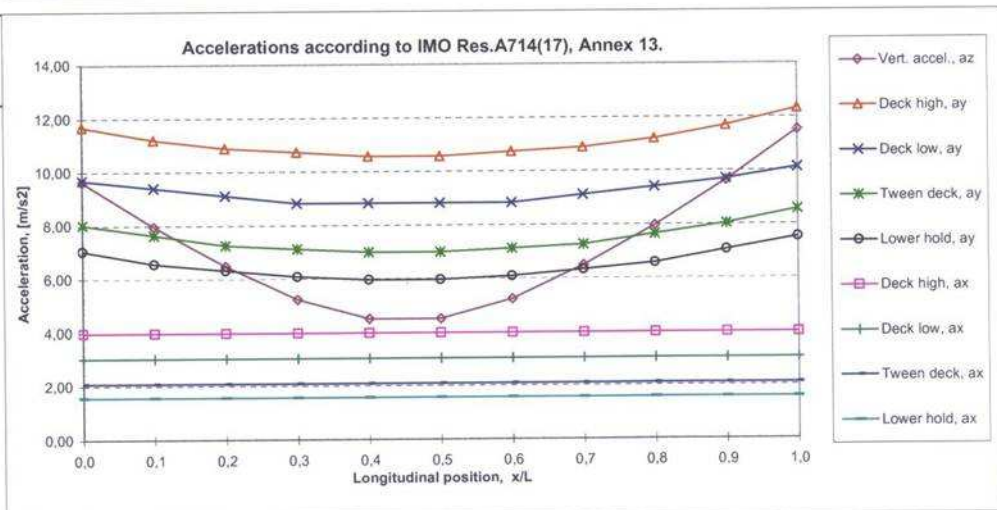

CARGO SECURING MANUAL FOR M/S TEST VESSEL

Vessel Name: M/S Test Vessel		Ship Id:										
Accelerations according to Annex 13 to IMO Res. A714(17)												
Transverse acceleration a_y in m/s^2												Long acc a_z in m/s^2
Long. position:	0,0	0,1	0,2	0,3	0,4	0,5	0,6	0,7	0,8	0,9	1,0	
Deck, high	16,78	16,10	15,65	15,42	15,19	15,19	15,42	15,65	16,10	16,78	17,69	3,98
Deck, low	12,86	12,48	12,09	11,71	11,71	11,71	11,71	12,09	12,48	12,86	13,44	3,04
Tween-deck	9,68	9,22	8,75	8,59	8,43	8,43	8,59	8,75	9,22	9,68	10,31	2,09
Lower hold	7,92	7,39	7,12	6,85	6,72	6,72	6,85	7,12	7,39	7,92	8,46	1,57
Vertical acceleration a_z in m/s^2												
	9,63	7,96	6,49	5,24	4,50	4,50	5,24	6,49	7,96	9,63	11,52	

Note! B/GM < 7 Accelerations are extrapolated outside the range given in Annex 13.

Note!
These accelerations
apply only
for GM=2,50m

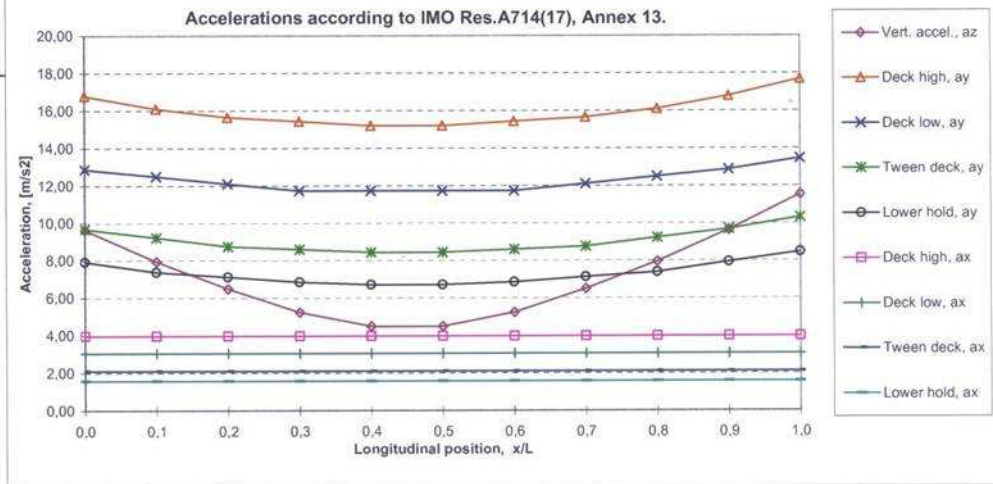

4.2 Application of portable securing devices

- .1 duration of the voyage;
- .2 geographical area of the voyage with particular regard to the minimum safe operational temperature of the portable securing devices;
- .3 sea conditions which may be expected;
- .4 dimensions, design and characteristics of the ship;
- .5 expected static and dynamic forces during the voyage;
- .6 type and packaging of cargo units;
- .7 intended stowage pattern of the cargo units; and
- .8 mass and dimensions of the cargo units.

Appendix II – Manual procedure for calculation of lashings

Annex 13 to the CSS Code and Amendments to the Code of Safe Practice for Cargo Stowage and Securing (IMO MSC/Circ.1026).

Assumption of external forces

External forces to a cargo unit in longitudinal, transverse and vertical directions should be obtained using the formula:

$$F_{(x,y,z)} = ma_{(x,y,z)} + F_{w(x,y)} + F_{s(x,y)}$$

where

- $F_{(x,y,z)}$ = longitudinal, transverse and vertical forces
- m = mass of unit
- $a_{(x,y,z)}$ = longitudinal, transverse and vertical accelerations (see table 2)
- $F_{w(x,y)}$ = longitudinal and transverse forces by wind pressure
- $F_{s(x,y)}$ = longitudinal and transverse forces by sea sloshing

The basic acceleration data are presented in table 2.

Transverse acceleration a_y in m/s^2										Longitudinal acceleration a_x in m/s^2		
on deck, high	7.1	6.9	6.8	6.7	6.7	6.8	6.9	7.1	7.4	3.8		
on deck, low	6.5	6.3	6.1	6.1	6.1	6.1	6.3	6.5	6.7	2.9		
'tween-deck	5.9	5.6	5.5	5.4	5.4	5.5	5.6	5.9	6.2	2.0		
lower hold	5.5	5.3	5.1	5.0	5.0	5.1	5.3	5.5	5.9	1.5		
	0	0.1	0.2	0.3	0.4	0.5	0.6	0.7	0.8	0.9	L	
Vertical acceleration a_z in m/s^2												
	7.6	6.2	5.0	4.3	4.3	5.0	6.2	7.6	9.2			

Table 2 - Basic acceleration data

Remarks:

The given transverse acceleration figures include components of gravity, pitch and heave parallel to the deck. The given vertical acceleration figures do not include the static weight component.

The basic acceleration data are to be considered as valid under the following operational conditions:

- .1 Operation in unrestricted area;
- .2 Operation during the whole year;
- .3 Duration of the voyage is 25 days;
- .4 Length of ship is 100 m;
- .5 Service speed is 15 knots;
- .6 $B/GM \geq 13$ (B: breadth of ship, GM: metacentric height).

CARGO SECURING MANUAL FOR M/S TEST VESSEL

For operation in a restricted area, reduction of these figures may be considered, taking into account the season of the year and the duration of the voyage.

For ships of a length other than 100 m and a service speed other than 15 knots, the acceleration figures should be corrected by a factor given in table 3.

Length [m] Speed [kN]	30	40	50	60	70	80	90	100	120	140	160	180	200	250	300
9	1,37	1,31	1,20	1,09	1,00	0,92	0,85	0,79	0,70	0,63	0,57	0,53	0,49	0,41	0,36
12	1,56	1,47	1,34	1,22	1,12	1,03	0,96	0,90	0,79	0,72	0,65	0,60	0,56	0,48	0,42
15	1,75	1,64	1,49	1,36	1,24	1,15	1,07	1,00	0,89	0,80	0,73	0,68	0,63	0,55	0,48
18	1,94	1,80	1,64	1,49	1,37	1,27	1,18	1,10	0,98	0,89	0,82	0,76	0,71	0,61	0,54
21	2,13	1,96	1,78	1,62	1,49	1,38	1,29	1,21	1,08	0,98	0,90	0,83	0,78	0,68	0,60
24	2,32	2,13	1,93	1,76	1,62	1,50	1,40	1,31	1,17	1,07	0,98	0,91	0,85	0,74	0,66

Table 3 – Correction factors for length and speed

For length/speed combinations not directly tabulated, the following formula may be used to obtain the correction factor with v = speed in knots and L = length between perpendiculars in metres:

$$\text{correction factor} = \left(0.345 \cdot \frac{v}{\sqrt{L}} \right) + \frac{(58.62 \cdot L - 1034.5)}{L^2}$$

This formula shall not be used for ship lengths less than 50 m or more than 300 m.

In addition, for ships with B/GM less than 13, only the transverse acceleration figures should be corrected by a factor given in Table 4.

B / GM	4	5	6	7	8	9	10	11	12	13 →
on deck, high	2,30	1,96	1,72	1,56	1,40	1,27	1,19	1,11	1,05	1,00
on deck, low	1,92	1,70	1,53	1,42	1,30	1,21	1,14	1,09	1,04	1,00
Tween-deck	1,54	1,42	1,33	1,26	1,19	1,14	1,09	1,06	1,03	1,00
lower hold	1,31	1,24	1,19	1,15	1,12	1,09	1,06	1,04	1,02	1,00

Table 4 - Correction factors for B/GM < 13

The following cautions should be observed:

In the case of marked roll resonance with amplitudes above + 30°, the given figures of transverse acceleration may be exceeded. Effective measures should be taken to avoid this condition.

In the case of heading into the seas at high speed with marked slamming shocks, the given figures of longitudinal and vertical acceleration may be exceeded. An appropriate reduction of speed should be considered.

In the case of running before large stern or quartering seas with a stability which does not amply exceed the accepted minimum requirements, large roll amplitudes must be expected with transverse accelerations greater than the figures given. An appropriate change of heading should be considered.

Forces by wind and sea to cargo units above the weather deck should be accounted for by simple approach:

$$\begin{aligned} \text{force by wind pressure} &= 1 \text{ kN/m}^2 \\ \text{force by sea sloshing} &= 1 \text{ kN/m}^2 \end{aligned}$$

Sloshing by sea can induce forces much greater than the figure given above. This figure should be considered as remaining unavoidable after adequate measures to prevent overcoming seas.

Sea sloshing forces need only be applied to height of deck cargo up to 2m above the weather deck or hatch top.

For voyages in a restricted area, sea sloshing forces may be neglected.

Balance of forces – Advanced method

Friction contributes towards prevention of sliding the following friction coefficients (μ) should be applied.

Materials in contact	Friction coefficient, (μ)
timber-timber, wet or dry	0,4
steel-timber or steel-rubber	0,3
steel-steel, dry	0,1
steel-steel, wet	0,0

Table 5 – Friction coefficients

The balance calculation should preferably be carried out for:

- transverse sliding in port and starboard directions;
- transverse tipping in port and starboard directions;
- longitudinal sliding under conditions of reduced friction in forward and aft directions

In the case of symmetrical securing arrangements, one appropriate calculation is sufficient.

1. Transverse sliding

The balance calculation should meet the following condition (see also figure 1):

$$F_y \leq \mu m g + CS_1 f_1 + CS_2 f_2 + \dots + CS_n f_n$$

where

- n is the number of lashings being calculated
- F_y is transverse force from load assumption (kN)
- μ is friction coefficient
- m is mass of the cargo unit (t)
- g is gravity acceleration of earth = 9.81 m/s²
- CS is calculated strength of transverse securing devices (kN)

$$CS = \frac{MSL}{1,5}$$

f is a function of μ and the vertical securing angle ∞ (see table 6).

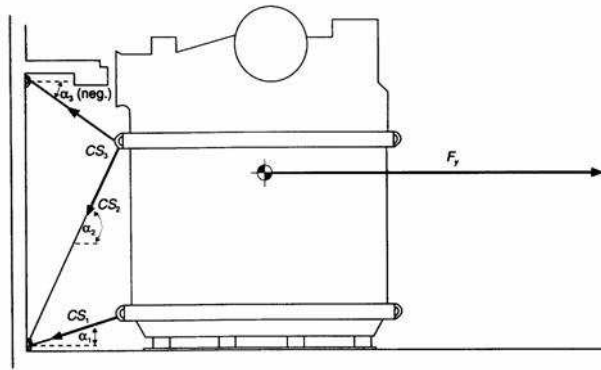

Figure 1 - Balance of transverse forces

A vertical securing angle α greater than 60° will reduce the effectiveness of this particular securing device in respect to sliding of the unit. Disregarding of such devices from the balance of forces should be considered, unless the necessary load is gained by the imminent tendency to tipping or by a reliable pre-tensioning of the securing device and maintaining the pre-tension throughout the voyage.

Any horizontal securing angle, i.e. deviation from the transverse direction, should not exceed 30° , otherwise an exclusion of this securing device from the transverse sliding balance should be considered.

α μ	-30°	-20°	-10°	0°	10°	20°	30°	40°	50°	60°	70°	80°	90°
0,3	0,72	0,84	0,93	1,00	1,04	1,04	1,02	0,96	0,87	0,76	0,62	0,47	0,30
0,1	0,82	0,91	0,97	1,00	1,00	0,97	0,92	0,83	0,72	0,59	0,44	0,27	0,10
0,0	0,87	0,94	0,98	1,00	0,98	0,94	0,87	0,77	0,64	0,50	0,34	0,17	0,00

Table 6 - f -Values as a function of α and μ

Remark: $f = \mu \sin \alpha + \cos \alpha$

2. Transverse tipping

This balance calculation should meet the following condition (see also figure 2):

$$F_y a \leq b m g + CS_1 c_1 + CS_2 c_2 + \dots + CS_n c_n$$

Where

F_y, m, g, CS, n are as explained under 1, Transverse sliding

- a is lever-arm of tipping (m) (see figure 2)
- b is lever-arm of stability (m) (see figure 2)
- c is lever-arm of securing force (m) (see figure 2)

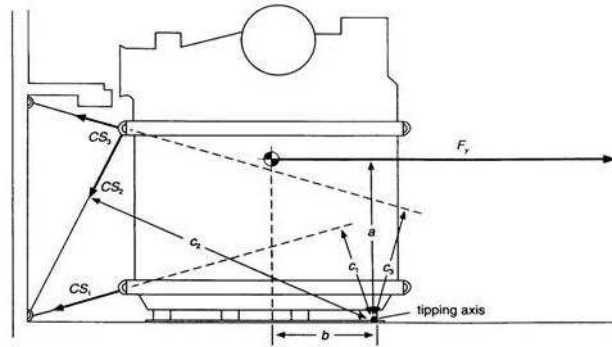

Figure 2 - Balance of transverse moments

3. Longitudinal sliding

Under normal conditions the transverse securing devices provide sufficient longitudinal components to prevent longitudinal sliding. If in doubt, a balance calculation should meet the following condition:

$$F_x \leq \mu (m g - F_z) + CS_1 f_1 + CS_2 f_2 + \dots + CS_n f_n$$

where

- F_x is longitudinal force from load assumption (kN)
- μ, m, g, f, n are as explained under 1, Transverse sliding
- F_z is vertical force from load assumption (kN)
- CS is calculated strength of longitudinal securing devices (kN)

$$CS = \frac{MSL}{1,5}$$

Remark: Longitudinal components of transverse securing devices should not be assumed greater than 0.5 CS.

Balance of forces – Alternative Method

This alternative method allows a more precise consideration of horizontal securing angles.

Securing devices usually do not have a pure longitudinal or transverse direction in practice but have an angle β in the horizontal plane. This horizontal securing angle β is defined in this annex as the angle of deviation from the transverse direction. The angle β is to be scaled in the quadrant mode, i.e. between 0° and 90° .

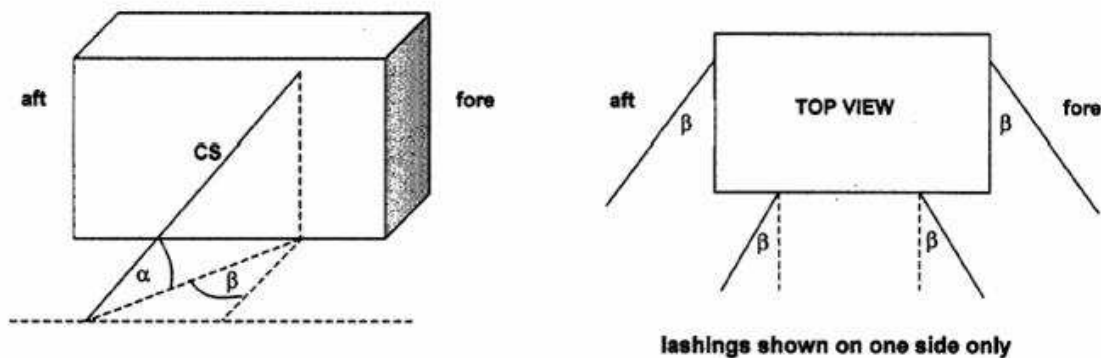

Figure 3 – Definition of the vertical and horizontal securing angles α and β

A securing device with an angle β develops securing effects both in longitudinal and transverse direction, which can be expressed by multiplying the calculated strength CS with the appropriate values of f_x or f_y . The values of f_x and f_y can be obtained from Table 7.

Table 7 consists of five sets of figures, one each for the friction coefficients $\mu = 0.4, 0.3, 0.2, 0.1$ and 0 . Each set of figures is obtained by using the vertical angle α and horizontal angle β . The value of f_x is obtained when entering the table with β from the right while f_y is obtained when entering with β from the left, using the nearest tabular value for α and β . Interpolation is not required but may be used.

The balance calculations are made in accordance with the following formulae:

$$\text{Transverse sliding} : Fy \leq \mu \cdot m \cdot g + fy_1 \cdot CS_1 + \dots + fy_n \cdot CS_n$$

$$\text{Longitudinal sliding} : Fx \leq \mu \cdot (m \cdot g - Fz) + fx_1 \cdot CS_1 + \dots + fx_n \cdot CS_n$$

$$\text{Transverse tipping} : Fy \cdot a \leq b \cdot m \cdot g + 0,9(CS_1 \cdot c_1 + CS_2 \cdot c_2 + \dots + CS_n \cdot c_n)$$

Caution:

Securing devices, which have a vertical angle α of less than 45° in combination with horizontal angle β greater than 45° , should not be used in the balance of transverse tipping in the above formula.

All symbols used in these formulae have the same meaning as defined under Balance of forces – Advanced method except f_x and f_y , obtained from Table 7, and CS is as follows:

$$CS = \frac{MSL}{1,35}$$

Table 7.1 for $\mu = 0.4$

β for f_y	α														β for f_x
	-30	-20	-10	0	10	20	30	40	45	50	60	70	80	90	
0	0.67	0.80	0.92	1.00	1.05	1.08	1.07	1.02	0.99	0.95	0.85	0.72	0.57	0.40	90
10	0.65	0.79	0.90	0.98	1.04	1.06	1.05	1.01	0.98	0.94	0.84	0.71	0.56	0.40	80
20	0.61	0.75	0.86	0.94	0.99	1.02	1.01	0.98	0.95	0.91	0.82	0.70	0.56	0.40	70
30	0.55	0.68	0.78	0.87	0.92	0.95	0.95	0.92	0.90	0.86	0.78	0.67	0.54	0.40	60
40	0.46	0.58	0.68	0.77	0.82	0.86	0.86	0.84	0.82	0.80	0.73	0.64	0.53	0.40	50
50	0.36	0.47	0.56	0.64	0.70	0.74	0.76	0.75	0.74	0.72	0.67	0.60	0.51	0.40	40
60	0.23	0.33	0.42	0.50	0.56	0.61	0.63	0.64	0.64	0.63	0.60	0.55	0.48	0.40	30
70	0.10	0.18	0.27	0.34	0.41	0.46	0.50	0.52	0.52	0.53	0.52	0.49	0.45	0.40	20
80	-0.05	0.03	0.10	0.17	0.24	0.30	0.35	0.39	0.41	0.42	0.43	0.44	0.42	0.40	10
90	-0.20	-0.14	-0.07	0.00	0.07	0.14	0.20	0.26	0.28	0.31	0.35	0.38	0.39	0.40	0

Table 7.2 for $\mu = 0.3$

β for f_y	α														β for f_x
	-30	-20	-10	0	10	20	30	40	45	50	60	70	80	90	
0	0.72	0.84	0.93	1.00	1.04	1.04	1.02	0.96	0.92	0.87	0.76	0.62	0.47	0.30	90
10	0.70	0.82	0.92	0.98	1.02	1.03	1.00	0.95	0.91	0.86	0.75	0.62	0.47	0.30	80
20	0.66	0.78	0.87	0.94	0.98	0.99	0.96	0.91	0.88	0.83	0.73	0.60	0.46	0.30	70
30	0.60	0.71	0.80	0.87	0.90	0.92	0.90	0.86	0.82	0.79	0.69	0.58	0.45	0.30	60
40	0.51	0.62	0.70	0.77	0.81	0.82	0.81	0.78	0.75	0.72	0.64	0.54	0.43	0.30	50
50	0.41	0.50	0.58	0.64	0.69	0.71	0.71	0.69	0.67	0.64	0.58	0.50	0.41	0.30	40
60	0.28	0.37	0.44	0.50	0.54	0.57	0.58	0.58	0.57	0.55	0.51	0.45	0.38	0.30	30
70	0.15	0.22	0.28	0.34	0.39	0.42	0.45	0.45	0.45	0.45	0.43	0.40	0.35	0.30	20
80	0.00	0.06	0.12	0.17	0.22	0.27	0.30	0.33	0.33	0.34	0.35	0.34	0.33	0.30	10
90	-0.15	-0.10	-0.05	0.00	0.05	0.10	0.15	0.19	0.21	0.23	0.26	0.28	0.30	0.30	0

Table 7.3 for $\mu = 0.2$

β for fy	α														β for fx
	-30	-20	-10	0	10	20	30	40	45	50	60	70	80	90	
0	0.77	0.87	0.95	1.00	1.02	1.01	0.97	0.89	0.85	0.80	0.67	0.53	0.37	0.20	90
10	0.75	0.86	0.94	0.98	1.00	0.99	0.95	0.88	0.84	0.79	0.67	0.52	0.37	0.20	80
20	0.71	0.81	0.89	0.94	0.96	0.95	0.91	0.85	0.81	0.76	0.64	0.51	0.36	0.20	70
30	0.65	0.75	0.82	0.87	0.89	0.88	0.85	0.79	0.75	0.71	0.61	0.48	0.35	0.20	60
40	0.56	0.65	0.72	0.77	0.79	0.79	0.76	0.72	0.68	0.65	0.56	0.45	0.33	0.20	50
50	0.46	0.54	0.60	0.64	0.67	0.67	0.66	0.62	0.60	0.57	0.49	0.41	0.31	0.20	40
60	0.33	0.40	0.46	0.50	0.53	0.54	0.53	0.51	0.49	0.47	0.42	0.36	0.28	0.20	30
70	0.20	0.25	0.30	0.34	0.37	0.39	0.40	0.39	0.38	0.37	0.34	0.30	0.26	0.20	20
80	0.05	0.09	0.14	0.17	0.21	0.23	0.25	0.26	0.26	0.26	0.26	0.25	0.23	0.20	10
90	-0.10	-0.07	-0.03	0.00	0.03	0.07	0.10	0.13	0.14	0.15	0.17	0.19	0.20	0.20	0

Table 7.4 for $\mu = 0.1$

β for fy	α														β for fx
	-30	-20	-10	0	10	20	30	40	45	50	60	70	80	90	
0	0.82	0.91	0.97	1.00	1.00	0.97	0.92	0.83	0.78	0.72	0.59	0.44	0.27	0.10	90
10	0.80	0.89	0.95	0.98	0.99	0.96	0.90	0.82	0.77	0.71	0.58	0.43	0.27	0.10	80
20	0.76	0.85	0.91	0.94	0.94	0.92	0.86	0.78	0.74	0.68	0.56	0.42	0.26	0.10	70
30	0.70	0.78	0.84	0.87	0.87	0.85	0.80	0.73	0.68	0.63	0.52	0.39	0.25	0.10	60
40	0.61	0.69	0.74	0.77	0.77	0.75	0.71	0.65	0.61	0.57	0.47	0.36	0.23	0.10	50
50	0.51	0.57	0.62	0.64	0.65	0.64	0.61	0.56	0.53	0.49	0.41	0.31	0.21	0.10	40
60	0.38	0.44	0.48	0.50	0.51	0.50	0.48	0.45	0.42	0.40	0.34	0.26	0.19	0.10	30
70	0.25	0.29	0.32	0.34	0.35	0.36	0.35	0.33	0.31	0.30	0.26	0.21	0.16	0.10	20
80	0.10	0.13	0.15	0.17	0.19	0.20	0.20	0.20	0.19	0.19	0.17	0.15	0.13	0.10	10
90	-0.05	-0.03	-0.02	0.00	0.02	0.03	0.05	0.06	0.07	0.08	0.09	0.09	0.10	0.10	0

Table 7.5 for $\mu = 0.0$

β for fy	α														β for fx
	-30	-20	-10	0	10	20	30	40	45	50	60	70	80	90	
0	0.87	0.94	0.98	1.00	0.98	0.94	0.87	0.77	0.71	0.64	0.50	0.34	0.17	0.00	90
10	0.85	0.93	0.97	0.98	0.97	0.93	0.85	0.75	0.70	0.63	0.49	0.34	0.17	0.00	80
20	0.81	0.88	0.93	0.94	0.93	0.88	0.81	0.72	0.66	0.60	0.47	0.32	0.16	0.00	70
30	0.75	0.81	0.85	0.87	0.85	0.81	0.75	0.66	0.61	0.56	0.43	0.30	0.15	0.00	60
40	0.66	0.72	0.75	0.77	0.75	0.72	0.66	0.59	0.54	0.49	0.38	0.26	0.13	0.00	50
50	0.56	0.60	0.63	0.64	0.63	0.60	0.56	0.49	0.45	0.41	0.32	0.22	0.11	0.00	40
60	0.43	0.47	0.49	0.50	0.49	0.47	0.43	0.38	0.35	0.32	0.25	0.17	0.09	0.00	30
70	0.30	0.32	0.34	0.34	0.34	0.32	0.30	0.26	0.24	0.22	0.17	0.12	0.06	0.00	20
80	0.15	0.16	0.17	0.17	0.17	0.16	0.15	0.13	0.12	0.11	0.09	0.06	0.03	0.00	10
90	0.00	0.00	0.00	0.00	0.00	0.00	0.00	0.00	0.00	0.00	0.00	0.00	0.00	0.00	0

Remark: $f_x = \cos \alpha \cdot \sin \beta + \mu \cdot \sin \alpha$ $f_y = \cos \alpha \cdot \cos \beta + \mu \cdot \sin \alpha$

Calculated example 1 – Advanced method

Ship: L= 120 m ; B = 20 m ; GM = 1,4 m ; Speed = 15 knots

Cargo: m = 62 t; dimensions = 6 x 4 x 4 m
Stowage at 0,7L on deck, low

Lever arm of tipping: a = 1.8 m
Lever arm of stability: b = 2.0 m
Lever arm of securing force: c₁ = 1.0 m
c₂ = 2.8 m

Force by wind pressure:

Longitudinal direction = F_W = 4 m x 4 m x 1 kN/m² = 16 kN
Transverse direction = F_W = 6 x 4 = 24 kN

Force by sea pressure:

Longitudinal direction = F_S = 4 x 2 = 8 kN
Transverse direction = F_S = 6 x 2 = 12 kN

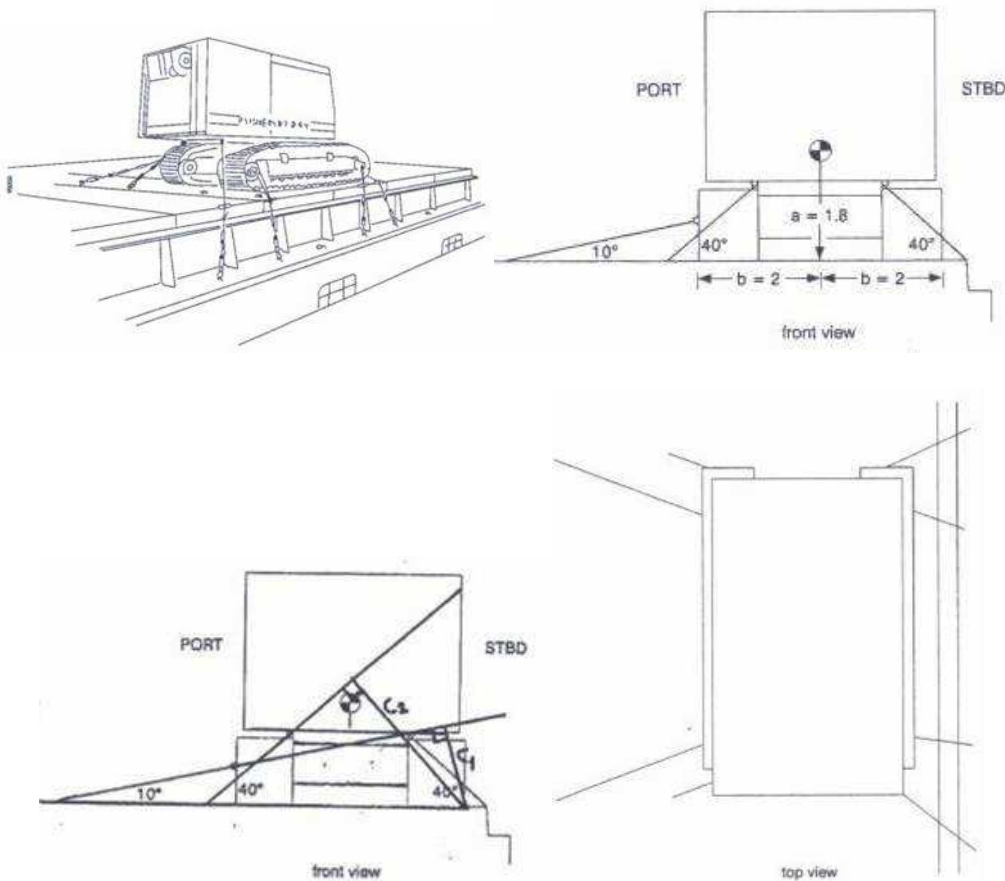

Securing material:

Wire rope:	breaking strength = 125 kN MSL = 100 kN
Shackles, turnbuckles, deck rings:	breaking strength = 180 kN MSL = 90 kN
Stowage on dunnage boards:	$\mu=0.3$ (Steel – timber)
Calculated strength (using lowest MSL):	$CS = 90/1.5 = 60$ kN

Securing Arrangement:

SIDE	n	CS	α	f*	c
STBD	4	60 kN	40°	0.96	2.8
PORT	2	60 kN	40°	0.96	2.8
PORT	2	60 kN	10°	1.04	1.0

*) Where f is taken from Table 6

External forces:

$$F_x = \text{mass} \times \text{long. acc.} \times \text{correction factor from table 3} + \text{long. force by wind} + \text{long. force by sea}$$

$$= 62 \times 2.9 \times 0.89 + 16 + 8 = 184 \text{ kN}$$

$$F_y = \text{mass} \times \text{trans. acc.} \times \text{correction factor from table 3} + \text{trans. force by wind} + \text{trans. force by sea}$$

$$= 62 \times 6.3 \times 0.89 + 24 + 12 = 384 \text{ kN}$$

$$F_z = \text{mass} \times \text{vertical acc.} \times \text{correction factor from table 3}$$

$$= 62 \times 6.2 \times 0.89 = 342 \text{ kN}$$

Balance of forces (STBD arrangement):

$$F_y < \mu \times m \times g + n \times CS \times f = \text{Friction force} + \text{Lashing force}$$

$$384 < 0.3 \times 62 \times 9.81 + 4 \times 60 \times 0.96$$

$$384 < 412 \quad \text{This is OK!}$$

Balance of forces (PORT arrangement):

$$F_y < \mu \times m \times g + n \times CS \times f + n \times CS \times f = \text{Friction force} + \text{Lashing force}$$

$$384 < 0.3 \times 62 \times 9.81 + 2 \times 60 \times 0.96 + 2 \times 60 \times 1.04$$

$$384 < 422 \quad \text{This is OK!}$$

Transverse tipping (STBD arrangement):

$$F_y \times a < b \times m \times g + n \times CS \times c = \text{Tipping moment} + \text{Lashing force}$$

$$384 \times 1.8 < 2 \times 62 \times 9.81 + 4 \times 60 \times 2.8$$

$$691 < 1888 \quad \text{No tipping, even without lashings!}$$

Calculated example 2

A cargo unit of 68 t mass is stowed on timber ($\mu = 0.3$) in the tween deck at 0.7 L of a vessel. L = 160 m, B = 24 m, v = 18 kn and GM = 1.5 m. Dimensions of the cargo unit are height = 2.4 m and width = 1.8 m.

The external forces are: $F_x = 112$ kN
 $F_y = 312$ kN
 $F_z = 346$ kN

The top view shows the overall securing arrangement with eight lashings.

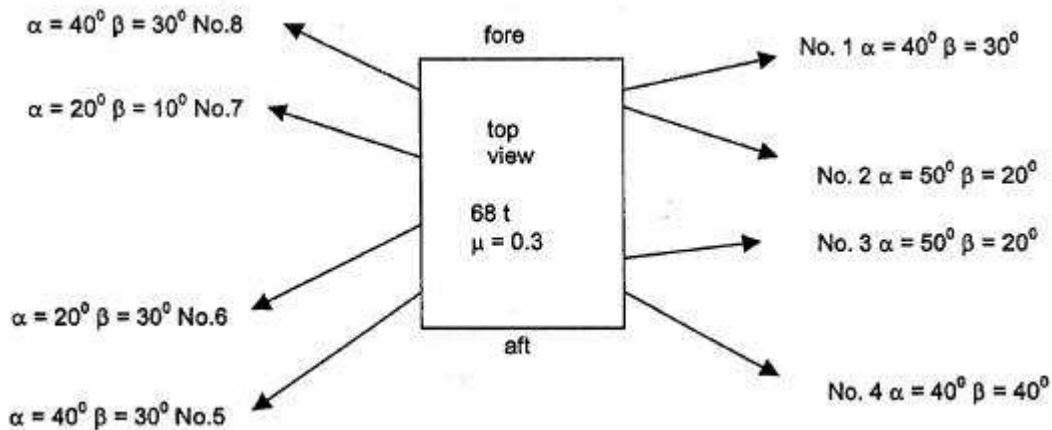

Calculation of balance of forces:

No.	MSL (kN)	CS (kN)	α	β	f _y	Cs x f _y	f _x	Cs x f _x
1	108	80	40° stbd	30° fwd	0.86	68.8 stbd	0.58	46.4 fwd
2	90	67	50° stbd	20° aft	0.83	55.6 stbd	0.45	30.2 aft
3	90	67	50° stbd	20° fwd	0.83	55.6 stbd	0.45	30.2 fwd
4	108	80	40° stbd	40° aft	0.78	62.4 stbd	0.69	55.2 aft
5	108	80	40° port	30° aft	0.86	68.8 port	0.58	46.4 aft
6	90	67	20° port	30° aft	0.92	61.6 port	0.57	38.2 aft
7	90	67	20° port	10° fwd	1.03	69.0 port	0.27	18.1 fwd
8	108	80	40° port	30° fwd	0.86	68.8 port	0.58	46.4 fwd

Transverse balance of forces (STBD arrangement) Nos. 1, 2, 3 and 4:

$$F_y < \mu \times m \times g + CS_1 \times f_{y1} + CS_2 \times f_{y2} + CS_3 \times f_{y3} + CS_4 \times f_{y4} = \text{Friction force} + \text{Lashing force}$$

$$312 < 0.3 \times 68 \times 9.81 + 68.8 + 55.6 + 55.6 + 62.4$$

$$312 < 443 \quad \text{this is OK!}$$

Transverse balance of forces (PORT arrangement) Nos. 5, 6, 7 and 8:

$$F_y < \mu \times m \times g + CS_5 \times f_{y5} + CS_6 \times f_{y6} + CS_7 \times f_{y7} + CS_8 \times f_{y8} = \text{Friction force} + \text{Lashing force}$$

$$312 < 0.3 \times 68 \times 9.81 + 68.8 + 61.6 + 69.0 + 68.8$$

$$312 < 468 \quad \text{this is OK!}$$

Longitudinal balance of forces (FWD arrangement) Nos. 1, 3, 7, 8:

$$F_x < \mu \times (m \times g - F_z) + CS_1 \times f_{x1} + CS_2 \times f_{x2} + CS_3 \times f_{x3} + CS_4 \times f_{x4} = \text{Frict. force} + \text{Lashing force}$$

$$112 < 0.3 (68 \times 9.81 - 346) + 46.4 + 30.2 + 18.1 + 46.4$$

$$112 < 237 \quad \text{this is OK!}$$

Longitudinal balance of forces (AFT arrangement) Nos. 2, 4, 5, 6:

$$F_x < \mu \times (m \times g - F_z) + CS_5 \times f_{x5} + CS_6 \times f_{x6} + CS_7 \times f_{x7} + CS_8 \times f_{x8} = \text{Frict. force} + \text{Lashing force}$$

$$112 < 0.3 (68 \times 9.81 - 346) + 30.2 + 55.2 + 46.4 + 38.2$$

$$112 < 266 \quad \text{this is OK!}$$

Transverse Tipping

Unless specific information is provided, the vertical centre of gravity of the cargo unit can be assumed to be at one half the height and the transverse centre of gravity at one half the width. Also, if the lashing is connected as shown in the sketch, instead of measuring c, the length of the lever from the tipping axis to the lashing CS, it is conservative to assume that it is equal to the width of the cargo unit.

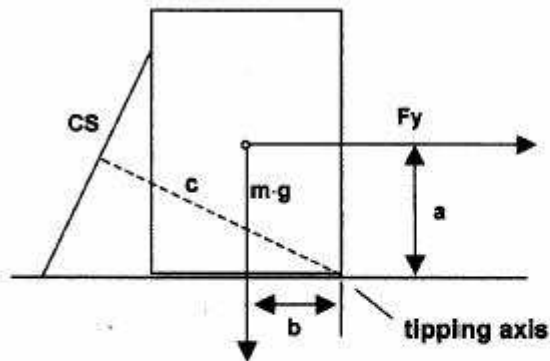

$$F_y \cdot a \leq b \cdot m \cdot g + 0.9 \cdot (CS_1 \cdot c_1 + CS_2 \cdot c_2 + CS_3 \cdot c_3 + CS_4 \cdot c_4)$$

$$312 \cdot 2.4/2 < 1.8/2 \cdot 68 \cdot 9.81 + 0.9 \cdot 1.8 \cdot (80 + 67 + 67 + 80)$$

$$374 < 600 + 476$$

$$374 < 1076 \quad \text{this is OK !}$$

Appendix III – Applicable Annexes from the CSS Code

ANNEX 1 Safe stowage and securing of containers on deck of ships which are not specially designed and fitted for the purpose of carrying containers.

1 Stowage

- 1.1 Containers carried on deck or on hatches of such ships should preferably be stowed in the fore-and-aft direction.
- 1.2 Containers should not extend over the ship's sides. Adequate supports should be provided when containers overhang hatches or deck structures.
- 1.3 Containers should be stowed and secured so as to permit safe access for personnel in the necessary operation of the ship.
- 1.4 Containers should at no time overstress the deck or hatches on which they are stowed.
- 1.5 Bottom-tier containers, when not resting on stacking devices, should be stowed on timber of sufficient thickness, arranged in such a way as to transfer the stack load evenly on to the structure of the stowage area.
- 1.6 When stacking containers, use should be made of locking devices, cones, or similar stacking aids, as appropriate, between them
- 1.7 When stowing containers on deck or hatches, the position and strength of the securing points should be taken into consideration.

If the individual gross weights of the containers are not known all 20ft units and all 40ft units should be assumed to have a gross weight of 20 and 26 tonnes respectively with the centre of gravity at the geometrical centre.

Care should be taken to ensure that the safe weight load of each individual container is not exceeded and that the gross and tare weights are accurately recorded and declared.

Stowing containers in cargo holds requires securing in solid blocks. The containers should be keyed to the tanktop and adequate inter-locking of units should be provided. The resulting block must be secured to the ship structure using common sense.

2. Securing

- 2.1 All containers should be effectively secured in such a way as to protect them from sliding and tipping. Hatch covers carrying containers should be adequately secured to the ship.
- 2.2 Containers should be secured using one of the three methods recommended in figure 1 or methods equivalent thereto.
- 2.3 Lashings should preferably consist of wire ropes or chains or material with equivalent strength and elongation characteristics.
- 2.4 Timber shoring should not exceed 2 m in length.

2.5 Wire clips should be adequately greased and tightened so that the dead end of the wire is visibly compressed (figure 2).

2.6 Lashings should be kept, when possible, under equal tension.

Care should be taken when:

- It is required to mix general break-bulk cargo with containers.
- Loading general cargo on top of containers.

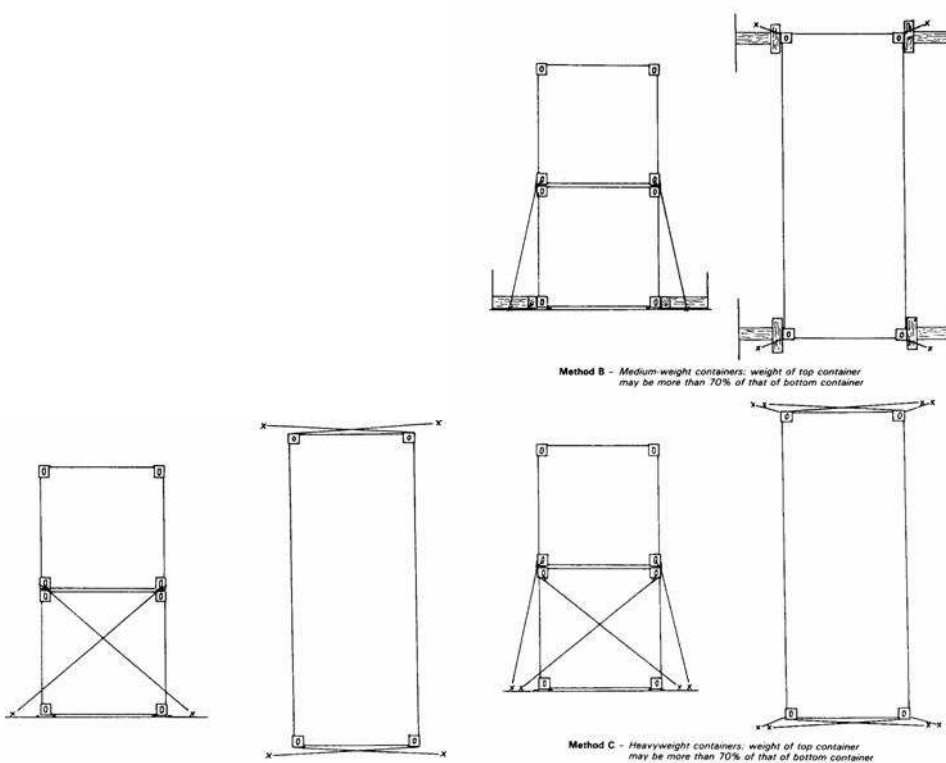

Figure 1 - Recommended methods of non-standardized securing of containers

Figure 1 (cont.) - Recommended methods of non-standardized securing of containers

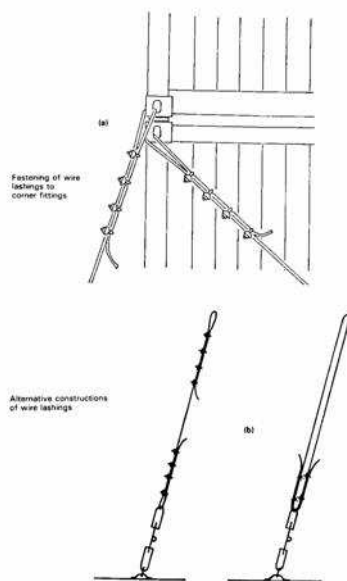

Figure 2

ANNEX 2 Safe stowage and securing of portable tanks.

1 Introduction

- 1.1 The provisions of this annex apply to a portable tank, which in the context of this annex, means a tank which is not permanently secured on board the vessel and has a capacity of more than 450 l and a shell fitted with external stabilising members and items of service equipment and structural equipment necessary for the transport of liquids, solids or gases.
- 1.2 These provisions do not apply to tanks intended for the transport of liquids, solids or gases having a capacity of 450 l or less.

Note: The capacity for portable tanks for gases is 1000 l or more.

2 General Provisions for Portable Tanks

- 2.1 Portable tanks should be capable of being loaded and discharged without the need of removal of their structural equipment and be capable of being lifted onto and off the ship when loaded.
- 2.2 The applicable requirements of the International Convention for Safe Containers, 1972, as amended, should be fulfilled by any tankcontainer which meets the definition of a container within the terms of that Convention. Additionally, the provisions of section 13 of the General Introduction to the IMDG Code should be met when the tank will be used for the transport of dangerous goods.
- 2.3 Portable tanks should not be offered for shipment in an ullage condition liable to produce an unacceptable hydraulic force due to surge within the tank.
- 2.4 Portable tanks for the transport of dangerous goods should be certified in accordance with the provisions of the IMDG Code by the competent approval authority or a body authorised by that authority.

3 Portable Tank Arrangements

- 3.1 The external stabilising members of a portable tank may consist of skids or cradles and, in addition, the tank may be secured to a platform-based container. Alternatively, a tank may be fixed within a framework of ISO or non-ISO frame dimensions.
- 3.2 Portable tank arrangements should include fittings for lifting and securing onboard.

Note: All types of the aforementioned portable tanks may be carried on multipurpose ships but need special attention for lashing and securing onboard.

4 Cargo Information

- 4.1 The master should be provided with at least the following information:
 - .1 dimensions of the portable tank and commodity if non-dangerous and, if dangerous, the information required in accordance with the IMDG Code;
 - .2 the gross mass of the portable tank; and
 - .3 whether the portable tank is permanently secured onto a platform-based container or in a frame and whether securing points are provided.

5. Stowage

- 5.1 The typical distribution of accelerations of the ship should be borne in mind in deciding whether the portable tank will be stowed on or under deck.
- 5.2 Tanks should be stowed in the fore-and-aft direction on or under deck.
- 5.3 Tanks should be stowed so that they do not extend over the ship's side.
- 5.4 Tanks should be stowed so as to permit safe access for personnel in the necessary operation of the ship.
- 5.5 At no time should the tanks overstress the deck or hatches; the hatchcovers should be so secured to the ship that tipping of the entire hatchcover is prevented.

6. Securing against Sliding and Tipping

6.1 Non-standardized portable tanks

- 6.1.1 The securing devices on non-standardized portable tanks and on the ship should be arranged in such a way as to withstand the transverse and longitudinal forces, which may give rise to sliding and tipping. The lashing angles against sliding should not be higher than 25° and against tipping not lower than 45° to 60° (figure 1).

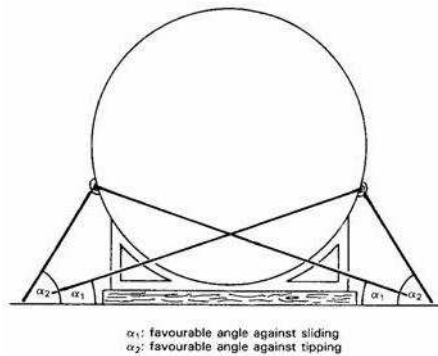

Figure 1 – Securing of portable tanks with favourable lashing angles

- 6.1.2 Whenever necessary, timber should be used between the deck surface and the bottom structure of the portable tank in order to increase friction. This does not apply to tanks on wooden units or with similar bottom material having a high coefficient of friction.
- 6.1.3 If stowage under deck is permitted, the stowage should be such that the portable non-standardized tank can be landed directly on its place and bedding.
- 6.1.4 Securing points on the tank should be of adequate strength and clearly marked.

Note: Securing points designed for road and rail transport may not be suitable for transport by sea.

- 6.1.5 Lashings attached to tanks without securing points should pass around the tank and both ends of the lashing should be secured to the same side of the tank (figure 2).

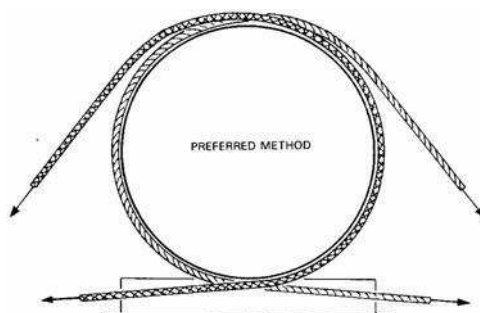

Figure 2 – Securing of portable tanks having no securing points

- 6.1.6 Sufficient securing devices should be arranged in such a way that each device takes its share of the load with an adequate factor of safety.
- 6.1.7 The structural strength of the deck or hatch components should be taken into consideration when tanks are carried thereon and when locating and affixing the securing devices.
- 6.1.8 Portable tanks should be secured in such a manner that no load is imposed on the tank or fittings in excess of those for which they have been designed.
- 6.2 Standardized portable tanks (tank-containers)
- 6.2.1 Standardized portable tanks with ISO frame dimensions should be secured according to the system of lashing with which the ship is equipped, taking into consideration the height of the tank above the deck and the ullage in the tank.

ANNEX 3 Safe stowage and securing of portable receptacles.

1 Introduction

- 1.1 A portable receptacle, in the context of these guidelines means a receptacle not being a portable tank, which is not permanently secured on board the ship and has a capacity of 1,000 l or less and has different dimensions in length, width, height and shape and which is used for the transport of gases or liquids.

2 Portable receptacles can be divided into:

- .1 cylinders of different dimensions without securing points and having a capacity not exceeding 150 l;
- .2 receptacles of different dimensions with the exception of cylinders in conformity with 2.1 having a capacity of not less than 100 l and not more than 1,000 l and whether or not fitted with hoisting devices of sufficient strength; and
- .3 assemblies, known as "frames", of cylinders in conformity with 2.1, the cylinders being interconnected by a manifold within the frame and held firmly together by metal fittings. The frames are equipped with securing and handling devices of sufficient strength (e.g. cylindrical receptacles are equipped with rolling hoops and receptacles are secured on skids).

3 Cargo Information

3.1 The master should be provided with at least the following information:

- .1 dimensions of the receptacle and commodity if non-dangerous and, if dangerous, the information as required in accordance with the IMDG Code;
- .2 gross mass of the receptacles; and

.3 whether or not the receptacles are equipped with hoisting devices of sufficient strength.

Note: Where in this annex the term receptacle is used, it is meant to include both receptacles and cylinders.

4 Stowage

- 4.1 The typical distribution of accelerations of the ship should be borne in mind in deciding whether the receptacles should be stowed on or under deck.
- 4.2 The receptacles should preferably be stowed in the fore-and-aft direction on or under deck.
- 4.3 Receptacles should be dunnaged to prevent their resting directly on a steel deck. They should be stowed and chocked as necessary to prevent movement unless mounted in a frame as a unit. Receptacles for liquefied gases should be stowed in an upright position.
- 4.4 When the receptacles are stowed in an upright position, they should be stowed in a block, cribbed or boxed in with suitable and sound timber. The box or crib should be dunnaged underneath to provide clearance from a steel deck. The receptacles in a box or crib should be braced to prevent movement. The box or crib should be securely chocked and lashed to prevent movement in any direction.

5 Securing Against Sliding And Shifting

5.1 Cylinders

Cylinders should be stowed fore-and-aft on athwart ships dunnage. Where practicable, the stow should be secured by using two or more wires, laid athwart ships prior to loading, and passed around the stow to securing points on opposite sides. The wires are tightened to make a compact stow by using appropriate tightening devices. During loading, wedges may be necessary to prevent cylinders rolling.

5.2 Cylinders in containers

Cylinders should, whenever practicable, be stowed upright with their valves on top and with their protective caps firmly in place. Cylinders should be adequately secured, so as to withstand the rigours of the intended voyage, by means of steel strapping or equivalent means led to lashing points on the container floor. When cylinders cannot be stowed upright in a closed container, they should be carried in an open top or a platform-based container.

5.3 Receptacles

Securing of receptacles stowed on or under deck should be as follows:

- .1 lashings should be positioned as shown in figure 1;
- .2 where possible, the hoisting devices on receptacles should be used to lash them; and
- .3 at regular times the lashings should be checked and re-tightened.

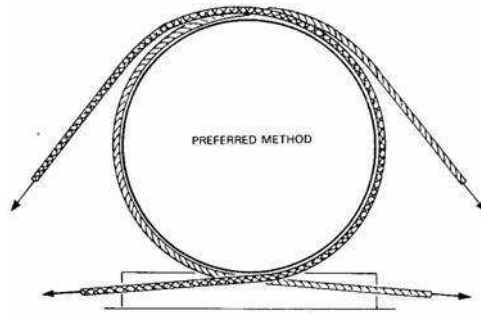

Figure 1 – Securing of receptacles having no securing points

ANNEX 4 Safe stowage and securing of wheel-based (rolling) cargoes

1 Introduction

Wheel-based cargoes, in the context of these guidelines, are all cargoes which are provided with wheels on tracks, including those which are used for the stowage and transport of other cargoes, except trailers and roadtrains, but including buses, military vehicles with or without tracks, tractors, earth-moving equipment, rolltrailers, etc.

2 General Recommendations

- 2.1 The cargo spaces in which wheel-based cargo is to be stowed should be dry, clean and free from grease and oil.
- 2.2 Wheel-based cargoes should be provided with adequate and clearly marked securing points or other equivalent means of sufficient strength to which lashings may be applied.
- 2.3 Wheel-based cargoes which are not provided with securing points should have those places where lashings may be applied, clearly marked.
- 2.4 Wheel-based cargoes, which are not provided with rubber wheels or tracks with friction-increasing lower surfaces, should always be stowed on wooden dunnage or other friction-increasing material such as soft boards, rubber mats, etc.
- 2.5 When in stowage position, the brakes of a wheel-based unit, if so equipped, should be set.
- 2.6 Wheel-based cargoes should be secured to the ship by lashings made of material having strength and elongation characteristics at least equivalent to steel chain or wire.
- 2.7 Where possible, wheel-based cargoes, carried as part cargo, should be stowed close to the ship's side or in stowage positions which are provided with sufficient securing points of sufficient strength, or be block stowed from side to side of the cargo space.
- 2.8 To prevent any lateral shifting of wheel-based cargoes not provided with adequate securing points, such cargoes should, where practicable, be stowed close to the ship's side and close to each other, or be blocked off by other suitable cargo units such as loaded containers, etc.
- 2.9 To prevent the shifting of wheel-based cargoes, it is, where practicable, preferable to stow those cargoes in a fore-and-aft direction rather than athwart ships. If wheel-based cargoes are inevitably stowed athwart ships, additional securing of sufficient strength may be necessary.
- 2.10 The wheels of wheel-based cargoes should be blocked to prevent shifting.

- 2.11 Cargoes stowed on wheel-based units should be adequately secured to stowage platforms or, where provided with suitable means, to its sides. Any movable external components attached to a wheel-based unit, such as derricks, arms or turrets should be adequately locked or secured in position.

ANNEX 5 Safe stowage and securing of heavy cargo items such as locomotives, transformers, etc.

1 Cargo Information

The master should be provided with sufficient information on any heavy cargo offered for shipment so that he can properly plan its stowage and securing; the information should at least include the following:

- .1 gross mass;
- .2 principal dimensions with drawings or pictorial descriptions, if possible;
- .3 location of the centre of gravity;
- .4 bedding areas and particular bedding precautions if applicable;
- .5 lifting points or slinging positions; and
- .6 securing points, where provided, including details of their strength.

2 Location of Stowage

- 2.1 When considering the location for stowing a heavy cargo item, the typical distribution of accelerations on the ship should be kept in mind:

- .1 lower accelerations occur in the midship sections and below the weather deck; and
- .2 higher accelerations occur in the end sections and above the weather deck.

- 2.2 When heavy items are to be stowed on deck, the expected “weather side” of the particular voyage should be taken into account if possible.

- 2.3 Heavy items should preferably be stowed in the fore-and-aft direction.

3 Distribution of Weight

The weight of the item should be distributed in such a way as to avoid undue stress on the ship's structure. Particularly with the carriage of heavy items on decks or hatch covers, suitable beams of timber or steel of adequate strength should be used to transfer the weight of the item onto the ship's structure.

4 Cargo Stowed in Open Containers, on Platforms or Platform-based Containers

- 4.1 While the stowage and securing of open containers, ISO platforms or platform-based containers (flatracks) on a containership or a ship fitted or adapted for the carriage of containers should follow the information for that system. The stowage and securing of the cargo in such containers should be carried out in accordance with the *IMO/ILO Guidelines for Packing Cargo in Freight Containers or Vehicles*.

- 4.2 When heavy cargo items are carried on ISO platforms or platform-based containers (flat racks) the provisions of this annex should be followed.

- .1 The ISO standard platform, etc., used should be of a suitable type with regards to strength and MSL of the securing points.

- .2 The weight of the heavy cargo item should be properly distributed.
- .3 Where deemed necessary, the heavy cargo item(s) carried on ISO standard platform(s) or platform-based containers, etc., should not only be secured to the platform(s) or platform-based containers, etc., but also to neighbouring platform(s), etc., or to securing points located at fixed structure of the ship. The elasticity of the last-mentioned lashing should be sufficient in line with the overall elasticity of the stowage block underneath the heavy cargo item(s) in order to avoid overloading those lashings.

5 Securing Against Sliding and Tipping

- 5.1 Whenever possible, timber should be used between the stowage surface and the bottom of the unit in order to increase friction. This does not apply to items on wooden cradles or on rubber tyres or with similar bottom material having a high coefficient of friction.
- 5.2 The securing devices should be arranged in a way to withstand transverse and longitudinal forces which may give rise to sliding or tipping.
- 5.3 The optimum lashing angle against sliding is about 25°, while the optimum lashing angle against tipping is generally found between 45° and 60° (figure 1).

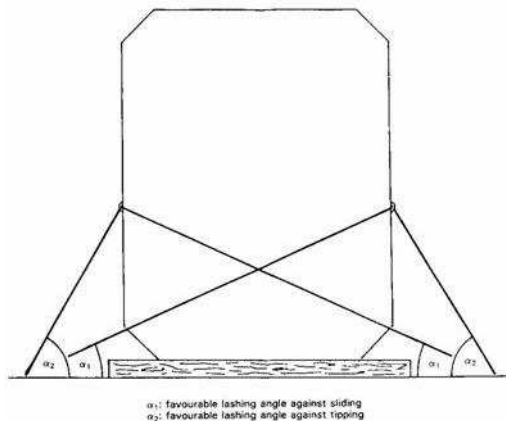

Figure 1 – Principles of securing heavy items against sliding and tipping

- 5.4 If a heavy cargo item has been dragged into position on greased skid boards or other means to reduce friction, the number of lashings used to prevent sliding should be increased accordingly.
- 5.5 If, owing to circumstances, lashings can be set at large angles only, sliding must be prevented by timber shoring, welded fittings or other appropriate means. Any welding should be carried out in accordance with accepted hot work procedures.

6 Securing Against Heavy Seas on Deck

Whilst it is recognised that securing cargo items against heavy seas on deck is difficult, all efforts should be made to secure such items and their supports to withstand such impact and special means of securing may have to be considered.

7 Heavy Cargo Items Projecting over the Ship's Side

Items projecting over the ship's side should be additionally secured by lashings acting in longitudinal and vertical directions.

8 Attachment of Lashings to Heavy Cargo Items

- 8.1 If lashings are to be attached to securing points on the item, these securing points should be of adequate strength and clearly marked. It should be borne in mind that securing points designed for road or rail transport may not be suitable for securing the items on board ship.
- 8.2 Lashings attached to items without securing points should pass around the item, or a rigid part thereof, and both ends of the lashing should be secured to the same side of the unit (figure 2).

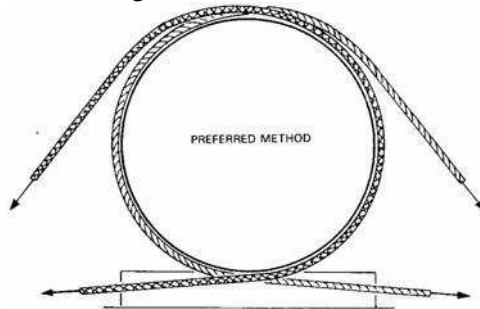

Figure 2 – Principle of securing heavy items having no suitable securing points

9. Composition and Application of Securing Devices

- 9.1 Securing devices should be assembled so that each component is of equal strength.
- 9.2 Connecting elements and tightening devices should be used in the correct way. Consideration should be given to any reduction of the strength of the lashings during the voyage through corrosion, fatigue or mechanical deterioration and should be compensated by using stronger securing material.
- 9.3 Particular attention should be paid to the correct use of wire, grips and clips. The saddle portion of the clip should be applied to the live load segment and the U-bolt to the dead or shortened end segment.
- 9.4 Securing devices should be arranged in such a way that each device takes its share of load according to its strength.
- 9.5 Mixed securing arrangements of devices with different strength and elongation characteristics should be avoided.

10 Maintenance of securing arrangements

- 10.1 The integrity of the securing arrangements should be maintained throughout the voyage.
- 10.2 Particular attention should be paid to the need for tight lashings, grips and clips and to prevent weakening through chafing. Timber cradles, beddings and shorings should be checked.
- 10.3 Greasing the tread of clips and turnbuckles increases their holding capacity and prevents corrosion.

11 Securing Calculation

- 11.1 Where necessary, the securing arrangements for heavy cargo items should be verified by an appropriate calculation in accordance with annex 13 to the Code.

ANNEX 7 Safe stowage and securing of heavy metal products

1 General

1.1 Heavy metal products in the context of this Code include any heavy item made of metal, such as bars, pipes, rods, plates, wire coils, etc.

1.2 The transport of heavy metal products by sea exposes the ship to the following principal hazards:

- .1 overstressing of the ship's structure if the permissible hull stress or permissible deck loading is exceeded;
- .2 overstressing of the ship's structure as a result of a short roll period caused by excessive metacentric height; and
- .3 cargo shifting because of inadequate securing resulting in a loss of stability or damage to the hull or both.

2 Recommendations

2.1 The cargo spaces in which heavy metal products are to be stowed should be clean, dry and free from grease and oil.

2.2 The cargo should be so distributed as to avoid undue hull stress.

2.3 The permissible deck and tank top loading should not be exceeded.

2.4 The following measures should be taken when stowing and securing heavy metal products:

- .1 cargo items should be stowed compactly from one side of the ship to the other leaving no voids between them and using timber blocks between items if necessary;
- .2 cargo should be stowed level whenever possible and practicable;
- .3 the surface of the cargo should be secured; and
- .4 the shoring should be made of strong, non-splintering wood and adequately sized to withstand the acceleration forces. One shoring should be applied to every frame of the ship but at intervals of not less than 1 m.

2.5 In the case of thin plates and small parcels, alternate fore-and-aft and athwart ships stowage has proved satisfactory. The friction should be increased by using sufficient dry dunnage or other material between the different layers.

2.6 Pipes, rails, rolled sections, billets, etc., should be stowed in the fore and-aft direction to avoid damage to the sides of the ship if the cargo shifts.

2.7 The cargo, and especially the topmost layer, can be secured by:

- .1 having other cargo stowed on top of it; or
- .2 lashing by wire, chocking off or similar means.

2.8 Whenever heavy metal products are not stowed from side to side of the ship, special care should be taken to secure such stowage's adequately.

2.9 Whenever the surface of the cargo is to be secured, the lashings should be independent of each other, exert vertical pressure on the surface of the cargo, and be so positioned that no part of the cargo is unsecured.

- 3 Wire Coils
 - 3.1 Wire coils should be stowed flat so that each coil rests against an adjacent coil. The coils in successive tiers should be stowed so that each coil overlaps the coils below.
 - 3.2 Wire coils should be tightly stowed together and substantial securing arrangements should be used. Where voids between coils are unavoidable or where there are voids at the sides or ends of the cargo space, the stow should be adequately secured.
 - 3.3 When securing wire coils stowed on their sides in several layers like barrels, it is essential to remember that, unless the top layer is secured, the coils lying in the stow can be forced out of the stow by the coils below on account of the ship's motions.

ANNEX 8 Safe stowage and securing of anchor chains

- 1 General
 - 1.1 Anchor chains for ships and offshore structures are usually carried in bundles or in continuous lengths.
 - 1.2 Provided certain safety measures are followed prior to, during and after stowage, anchor chains may be lowered directly onto the place of stowage in bundles without further handling, or stowed longitudinally either along the ship's entire cargo space or part thereof.
 - 1.3 If the cargo plans given in the ship's documentation contain no specific requirements, the cargo should be distributed over the lower hold and 'tween-decks in such a way that stability values thus obtained will guarantee adequate stability.
- 2 Recommendations
 - 2.1 Cargo spaces in which chains are stowed should be clean and free from oil and grease.
 - 2.2 Chains should only be stowed on surfaces which are permanently covered either by wooden ceiling or by sufficient layers of dunnage or other suitable friction-increasing materials. Chains should never be stowed directly on metal surfaces.
- 3 Stowage And Securing Of Chains In Bundles
 - 3.1 Chains in bundles, which are lifted directly onto their place of stowage without further handling, should be left with their lifting wires attached and should preferably be provided with additional wires around the bundles for lashing purposes.
 - 3.2 It is not necessary to separate layers of chain with friction-increasing material such as dunnage because chain bundles will grip each other. The top layer of chain bundles should be secured to both sides of the ship by suitable lashings. Bundles may be lashed independently or in a group, using the lifting wires.
- 4 Stowage and Securing of Chains which are Stowed Longitudinally
 - 4.1 Stowage of each layer of chain should, whenever possible and practicable, commence and terminate close to the ship's side. Care should be taken to achieve a tight stow.
 - 4.2 It is not necessary to separate layers of chain with friction-increasing material such as dunnage because chain layers will grip each other.

- 4.3 Bearing in mind the expected weather and sea conditions, the length and nature of the voyage and the nature of the cargo to be stowed on top of the chain, the top layer of each stow should be secured by lashings of adequate strength crossing the stow at suitable intervals and thus holding down the entire stow.

ANNEX 12 Safe stowing and securing of unit loads

1 Introduction

Unit load for the purposes of this annex means that a number of packages are either:

- .1 placed or stacked, and secured by strapping, shrink-wrapping or other suitable means, on a load board such as a pallet; or
- .2 placed in a protective outer packaging such as a pallet box; or
- .3 permanently secured together in a sling.

Note: A single large package such as a portable tank or receptacle, intermediate bulk container or freight container is excluded from the recommendations of this annex

2 Cargo Information

The master should be provided with at least the following information:

- .1 the total number of unit loads and commodity to be loaded;
- .2 the type of strapping or wrapping used;
- .3 the dimensions of a unit load in metres; and
- .4 the gross mass of a unit load in kilogrammes.

3 Recommendations

- 3.1 The cargo spaces of the ship in which unit loads will be stowed should be clean, dry and free from oil and grease.
- 3.2 The decks, including the tank top, should be flush all over.
- 3.3 The cargo spaces should preferably be of a rectangular shape, horizontally and vertically. Cargo spaces of another shape in forward holds or in 'tweendecks should be transformed into a rectangular shape both athwartships and longitudinally by the use of suitable timber (figure 1).

4 Stowage

- 4.1 The unit loads should be stowed in such a way that securing, if needed, can be performed on all sides of the stow.

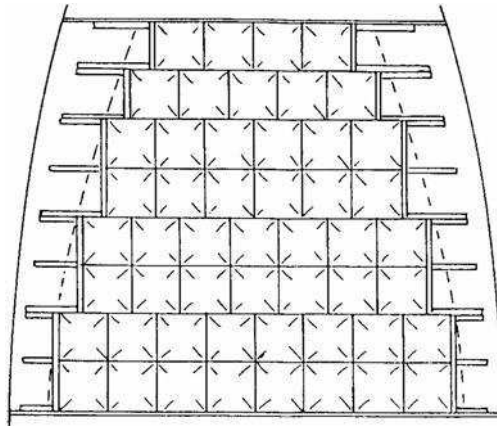

Figure 1 – Stowage and chocking of unit loads in a tapered stowage area (view from top)

- 4.2 The unit loads should be stowed without any void space between the loads and the ship's sides to prevent the unit loads from racking.
- 4.3 When unit loads have to be stowed on top of each other, attention should be paid to the strength of pallets and the shape and the condition of the unit loads.
- 4.4 Precautions should be taken when unit loads are mechanically handled to avoid damaging the unit loads.
- 5 Securing
 - 5.1 Block stowage should be ensured and no void space be left between the unit loads.
- 6 Securing when stowed athwart ships
 - 6.1 When unit loads are stowed in a lower hold or in a 'tween-deck against a bulkhead from side to side, gratings or plywood sheets should be positioned vertically against the stack of the unit loads. Wire lashings should be fitted from side to side keeping the gratings or plywood sheets tight against the stow.
 - 6.2 Additionally, lashing wires can be fitted at different spacing from the bulkhead over the stow to the horizontally placed wire lashings in order to further tighten the stow.
- 7 Stowage in a Wing of a Cargo Space and Free at Two Sides
 - 7.1 When unit loads are stowed in the forward or after end of a cargo space and the possibility of shifting in two directions exists, gratings or plywood sheets should be positioned vertically to the stack faces of the unit loads of the non-secured sides of the stow. Wire lashings should be taken around the stow from the wings to the bulkhead. Where the wires can damage the unit loads (particularly on the corners of the stow), gratings or plywood sheets should be positioned in such a way that no damage can occur on corners.
- 8 Stowage Free at Three Sides
 - 8.1 When unit loads are stowed against the ship's sides in such a way that shifting is possible from three sides, gratings or plywood sheets should be positioned vertically against the stack faces of the unit loads. Special attention should be paid to the corners of the stow to prevent damage to the unit loads by the wire lashings. Wire lashing at different heights should tighten the stow together with the gratings or plywood sheets at the sides (figure 2).

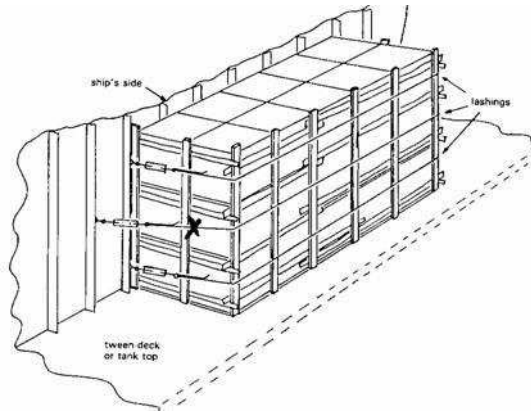

Figure 2 – Securing of units stowed at the ship's side

Note: Lashings must not place a sideways load on the frame/stiffener

9 General

- 9.1 Instead of gratings or plywood sheets, other possibilities are the use of aluminium stanchions or battens of sufficient strength.
- 9.2 During the voyage the wire lashings should be regularly inspected and slack wires should be re-tightened if necessary. In particular, after rough weather, wire lashings should be checked and re-tightened if necessary.

Appendix IV – LASHCON™ IMO USER GUIDE



LASHCON™ IMO
USER GUIDE

BY

DET NORSKE VERITAS

Version: 9.0
Date: 2003-12-08

1 General

1.1 Introduction

LASHCON™ is a MS EXCEL based calculation tool for evaluation of semi- and non-standardised securing arrangements.

The program calculates accelerations and balance of forces in semi- and non-standardised lashing arrangements in accordance with annex 13 to the Code of Safe Practice for Cargo Stowage and Securing (the CSS code) from IMO.

1.2 System requirements

LASHCON™ requires Microsoft Windows version 3.1 or later, with Microsoft Excel 5.0 installed. Resources needed to run Microsoft Excel 5.0 are described in “Microsoft Excel User’s Guide”.

1.3 User requirements

The user should be familiar with Microsoft products such as Excel and Word. This includes the use of mouse pointer.

NOTE: The decimal separator may differ from the examples given in this booklet.

Normally either “.” or “,” is used.

2. User guide

2.1 Input sequence

- Once LASHCON™ has been started, the following screen picture will appear:

		Code of Safe Practice for Cargo Stowage and Securing 2003 Edition, Annex 13		LASHCON IMO Version 9.0 December 2003		Sign: <input type="text"/> Time: 16:48 Date: 04.02.19	
<p>About LASHCON™: LASHCON is a MS EXCEL based calculation tool for control of lashing-arrangements for semi- and non-standardised cargo. The program is developed by Det Norske Veritas, and is based on the calculation procedures outlined in Annex 13 to the Code of Safe Practice for Cargo Stowage and Securing, 2003 Edition.</p> <p>Program assumptions: Reference is made to the User Manual.</p>							
Input of main vessel data:							Next page>>
Vessel Name:	Ship Id:	Lpp [m]:	B [m]:	V [kn]:	GM [m]:		
M/S Test Vessel	123456	73,5	14,0	10,0	1,8	Print	
NOTES:							
<p>This version of Lashcon IMO contains the procedures for calculation of accelerations and lashing arrangement as given in the Code of Safe Practice for Cargo Stowage and Securing, 2003 Edition, Annex 13.</p> <p>Following enhancements have been incorporated:</p> <ol style="list-style-type: none"> The range of validity for ship length has been extended down to L=30 m. The B/GM range has been extended down to B/GM = 4 by power series extrapolation. 							

- Input cells are marked white in LASHCON™. Not all input cells are necessary for successful computation. Ship name and identification is solely for user reference. Vessel main particulars are used for acceleration computation and must be filled in before proceeding. See 2.2 Input Data for details.

- After successful completion of the input data, click on the button “*Next Page >>*” proceed to the “*Cargo and lashing data sheet*”. The following picture will then appear:

		Code of Safe Practice for Cargo Stowage and Securing 2003 Edition, Annex 13		LASHCON IMO Version 9.0 December 2003				Sign: _____ Time: 16:48 Date: 04.02.19				
Input of cargo unit data Cargo unit specification: _____ Mass of cargo unit: m _____ ton Coefficient of friction: μ (-) ? Wind exposed area: A_w _____ m ² ? Sea exposed area: A_s _____ m ² ? Lever arm of tipping: a _____ m ? Lever arm of stableness: b _____ m ?			Give cargo unit stowage position Vertical: Deck, high ? Longitudinal: AP Calculation method: <input checked="" type="radio"/> Alternative calculation ? Recommended. <input type="radio"/> Advanced calculation ?									
Input of lashing data			1	2	3	4	5	6	7	8	9	10
Max securing load [kN]:			MSL									
Transverse lashing direction			[Dropdown]									
Longitudinal lashing direction			[Dropdown]									
Vertical securing angle [degr]:			α									
Vertical securing angle [degr]:			β									
Horizont. securing point distance:			d [m]									
RESULTS:												
Actual forces			Securing capacity [kN / kNm]				Accelerations Show Graph >>					
Transverse sliding force [kN]: 0,0			Transv. capacity: PS [kN] 0 OK		SB [kN] 0 OK		Transverse: $a_t = 10,71$ m/s ²					
Longitudinal sliding force [kN]: 0,0			Long. capacity: Fwd [kN] 0 OK		Aft [kN] 0 OK		Vertical: $a_v = 9,28$ m/s ²					
Cargo tipping moment [kNm] 0,0			Tipping capacity: PS [kN] 0 OK		SB [kN] 0 OK		Longitudinal: $a_l = 3,83$ m/s ²					
<<< Main Data			Print		Save to stack		Clear last		Clear stack		Show stack >>	
Main Vessel Data:												
Vessel Name:			Ship Id:		Lpp [m]:		B [m]:		V [kn]:		GM [m]:	
M/S Test Vessel			123456		73,50		14,00		10,00		1,80	

For help on input data, press the “?” button to the right of the respective input. The input parameters are the same as explained in “Code of Safe Practice for Cargo Stowage and Securing Annex 13.

- Fill in the in the “*Input of cargo unit data*” field.
- Select the “*Cargo unit stowage position*” (vertical and longitudinal) by using the drop-down selection boxes in the upper right corner of the screen.
- Select the desired method of calculation.
 - Advanced calculation, see 2.3 Calculation Methods
 - Alternative calculation, see 2.3 Calculation Methods
- Give the applicable lashing particulars
 - MSL of lashing. [kN]
 - Lashing direction for drop down boxes.
 - Vertical securing angle [deg]
 - Horizontal securing angle [deg] (Alternative method only.)
 - Horizontal securing point distance [m]

8. Calculation results are shown in the yellow area. **“Actual forces”** is the forces acting on the cargo unit due to the **“Accelerations”** at the given lashing position. **“Securing capacity”** is the accumulated lashing forces from applied lashings. If sufficient number of lashings is applied, compliance will be shown by **“OK”** in red fonts to the right of each capacity.
9. Acceleration data for the whole ship can be extracted from the **“Tables and graphs”** sheet. This can be accessed by either pressing the **“Show graph >>”** button or by pressing the **“Tables and graphs”** tab.

<input type="button" value="Return"/>		Vessel Name:										Ship Id:			
<input type="button" value="Print"/>		Accelerations according to Annex 13 to IMO Res. A714(17)													
		Transverse acceleration a_y in m/s^2										Long acc a_x in m/s^2			
Long position:		0,0	0,1	0,2	0,3	0,4	0,5	0,6	0,7	0,8	0,9	1,0			
Deck, high		10,71	10,28	9,99	9,84	9,70	9,70	9,84	9,99	10,28	10,71	11,29	3,83		
Deck, low		8,96	8,69	8,43	8,16	8,16	8,16	8,16	8,43	8,69	8,96	9,36	2,92		
Tween-deck		7,54	7,17	6,81	6,69	6,56	6,56	6,69	6,81	7,17	7,54	8,02	2,02		
Lower hold		6,70	6,25	6,02	5,79	5,68	5,68	5,79	6,02	6,25	6,70	7,16	1,51		
		Vertical acceleration a_z in m/s^2													
		9,28	7,66	6,25	5,04	4,34	4,34	5,04	6,25	7,66	9,28	11,09			

Note !
These accelerations apply only for GM=1,80m

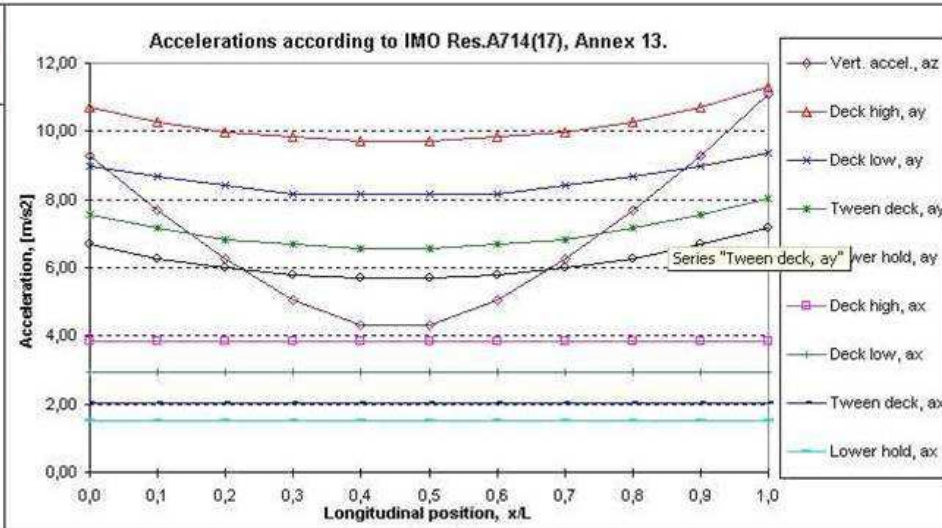

Chart and table showing the accelerations along the ship length, based on the annex 13 to the IMO CSS code.

2.2 Input data

Main ship data:

- Lpp - Length between perpendiculars in meters [m]
- B - Ship breadth in meters [m]
- V - Ship speed in knots [knots]
- GM - Ship GM value in meters [m]

Main cargo data:

- m - Mass of cargo unit in tonnes [ton]
- μ - Coefficient of friction [-]
- A_w - Wind exposed area in square meters. [m²]

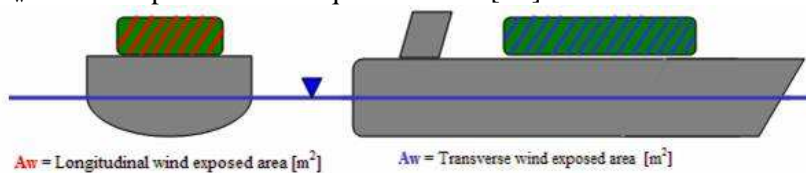

A_s - Sea exposed area, 2 meters above BL, in meters. [m²]

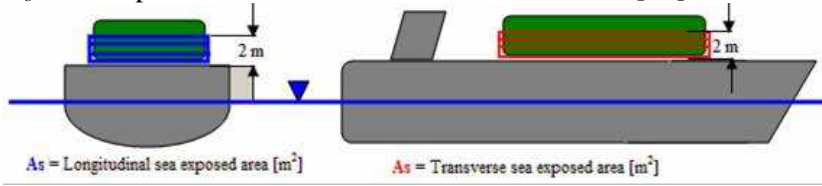

- a - Lever arm of tipping, i.e. height of cargo unit CG above deck, in meters. [m]
- b - Lever arm of stability in meters. [m]

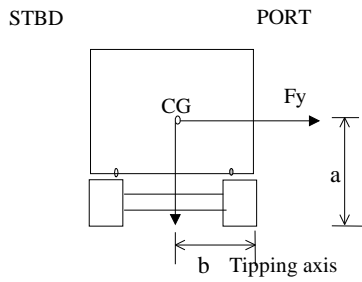

Advanced calculation, lashing parameters:

- MSL - Max securing load [kN]
- α - Vertical securing angle [degrees]
- d - Lever arm of securing force [m]

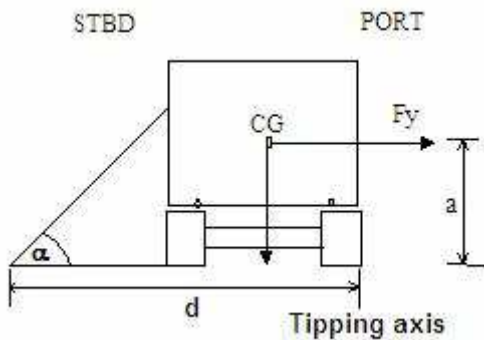

Alternative calculation, lashing parameters:

- MSL - Max securing load [kN]
- α - Vertical securing angle [degrees]
- β - Horizontal securing angle [degrees]
- d - Lever arm of securing force [m] (See Advanced Calculation, lashing parameters)

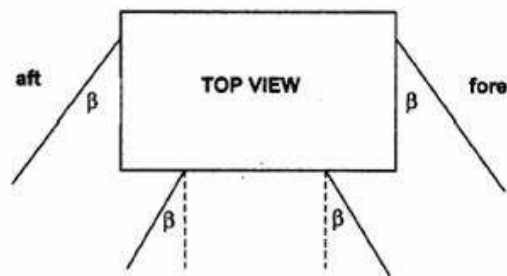
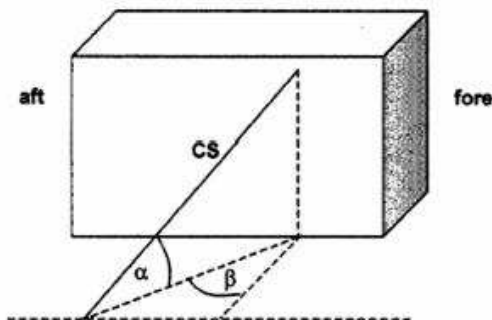

lashings shown on one side only

2.3 Calculation methods

Advanced calculation method

The advanced method is based on force equilibrium of internal inertia forces and external lashing forces. Additionally, the risk of tipping is evaluated on basis of moment equilibrium. Forces due to wind, sea and friction are accounted for. Elastic characteristics of lashings are not included.

In advanced calculations only the vertical angle of lashings, α is included. Calculated strength of lashing, CS , is $MSL / 1.5$.

For detailed theory outline, please refer to CSS, Annex 13.

Alternative calculation method

The alternative calculation method is based on force equilibrium of internal inertia forces and external lashing forces. Additionally, the risk of tipping is evaluated on basis of moment equilibrium. Forces due to wind, sea and friction are accounted for. Elastic characteristics of lashings are not included.

The alternative method accounts for both the vertical of lashings, α and horizontal angle of lashing β . The alternative method approach is regarded as more accurate than the advanced method. Hence the utilization of lashing strength is higher. Calculated strength of lashing, CS , is $MSL / 1.35$.

Which calculation method to choose?

The alternative calculation method is the most sophisticated with respect to force equilibrium. Hence, the allowable usage of the MSL is slightly higher. This method is therefore recommended. It should be noted that none of the calculation methods includes the elastic properties of the lashings. It is therefore important that the cargo unit is lashed with lashings of same type, with approximate equal elasticity. Lashing ropes and chains should not be combined. It is recommended to keep the lashings of approximately same lengths.

2.4 Special features of Lashcon IMO

Stack function:

LASHCON™ offers the possibility of saving your results in a stack. Lashing results, together with basic input is saved in a compact form in a table. In this way, the effect of different lashing arrangements or stowing positions can be compared in an easy manner.

Stack buttons:

“*Save to stack*”:
Current lashing data and results are saved to the stack.

“*Clear last*”:
Removes the last entry in the stack.

“*Clear stack*”:
Removes the contents of the entire stack.

“*Show stack*”:
Shows the stack.

2.5 Program assumptions

The calculation of accelerations and evaluation of lashing arrangements is based on the method described in annex 13 to the CSS code. For details on theory for evaluation of forces, please refer to CSS Annex 13. The following assumptions are directly quoted from the code:

A vertical securing angle α greater than 60° will reduce the effectiveness of this particular securing device in respect of sliding of the unit. Disregarding of such devices from the balance of forces should be considered, unless the necessary load is gained by the imminent tendency to tipping or by a reliable pre-tensioning of the securing device and maintaining the pre-tension throughout the voyage.

Any horizontal securing angle, i.e. deviation from the transverse direction should not exceed 30°, otherwise an exclusion of this securing device from the transverse sliding balance should be considered.

LASHCON™ applies to lashing arrangements with vertical securing angles in the range according to table 5 in annex 13, i.e. $-30^\circ \leq \alpha \leq 90^\circ$. Lashing angles outside this range may give corrupt results. In case such angle is given the program will give the following warning:

$\alpha < -30^\circ$ or $\alpha > 90^\circ$: **Warning! Securing angle outside range stated in annex 13.**

The acceleration figures shown in table 3 in annex 13 are basis for the calculation of accelerations in LASHCON™, and apply in principle to ships with $50 \text{ m} \leq L \leq 200 \text{ m}$, $9 \text{ kn} \leq V \leq 24 \text{ kn}$ and $B/GM \geq 7$.

In LASHCON™, however, the accelerations have been extrapolated by means of power series to apply for ships with $L > 30 \text{ m}$, and speed up to 25 knots. The B/GM has been extrapolated to apply down to $B/GM = 4$. LASHCON™ does not calculate transverse accelerations if $B/GM < 4$. If input parameters are outside the applicable range, the following warnings will appear:

$L > 200 \text{ m}$: **Warning! L > 200.**
Accelerations are extrapolated outside the range given in annex 13!

$B/GM < 7$: **Warning! B/GM < 7.**
Accelerations are extrapolated outside the range given in annex 13!

$B/GM < 4$: **Warning! B/GM < 4.**
Transverse accelerations are not calculated!

$V > 25 \text{ kn}$: **Warning! V > 25 kn.**
Accelerations are not calculated!

Explanation of variables is given in the Help-function in LASHCON™. A complete explanation of variables involved and a full set of assumptions may be found in annex 13.

Appendix V – Certification for fixed cargo securing devices

Insert in this Appendix the (DNV) product certificates for fixed cargo securing devices.

Appendix VI – Certification for portable cargo securing devices

Insert in this Appendix the product certificates for portable cargo securing devices