

Strength criteria in semi-analytical, large deflection analysis of stiffened plates in local and global bending

Lars Brubak*, Jostein Hellesland

Mechanics Division, Department of Mathematics, University of Oslo, P.O. Box 1053, NO-0316 Oslo, Norway

ARTICLE INFO

Article history:

Received 22 May 2007

Received in revised form

26 March 2008

Accepted 26 March 2008

Available online 2 June 2008

Keywords:

Strength criteria

Stiffener stiffness reduction criterion

Arbitrarily stiffened plates

Ultimate strength

Semi-analytical method

Large deflection theory

Rayleigh–Ritz method

ABSTRACT

Various strength criteria that may be used in semi-analytical methods for ultimate strength prediction of arbitrarily stiffened plates are studied. The main objective is to evaluate the applicability of the criteria in ultimate strength predictions of in-plane loaded plates, both in local and global bending. The equilibrium path is traced using large deflection theory and the Rayleigh–Ritz approach on an incremental form. The approach is able to account for the reserve strength of slender plates in the postbuckling region. Results are compared with fully nonlinear finite element analyses for a variety of plate dimensions and stiffeners with regular and irregular arrangements. Good agreement is obtained with a combination of a plate and a stiffener criterion. With the considered criteria included, the method is computationally very efficient and gives rather high numerical accuracy.

© 2008 Elsevier Ltd. All rights reserved.

1. Introduction

Stiffened plates in ships and other structures may be exposed to complex stress patterns due to simultaneously acting in-plane biaxial and shear stresses. In design of such elements, buckling and ultimate strength are important issues. Each individual stiffened plate must be dimensioned such that it is able to sustain the applied loads and deformations with a suitable margin of safety. In general cases in which explicit strength formulas [1,2] are not applicable, due to complex geometries, etc., ultimate strengths can be computed using nonlinear finite element or semi-analytical methods. Finite element analysis is impractical in many cases with a large number of individual stiffened plates to be analysed. In such contexts, semi-analytical methods represent an alternative approach as they are very computationally efficient. Such an approach is considered here.

A stiffened plate is able to carry loads beyond those causing yielding at the outer fibres, due to redistribution of plate stresses caused by formation of plastic regions. In semi-analytical methods, one approach for ultimate strength prediction is to account for plasticity in a simplified manner, such as in Paik and Lee [3], where the progressing plasticity is treated numerically by removing material in plastic regions. Another, and probably computationally more efficient approach, is to combine an elastic

model with a simplified strength criterion. For instance in Byklum [4], Brubak et al. [5], and Brubak and Hellesland [6,7], the von Mises' yield criterion for membrane stresses is used. This allows for some yielding to take place.

In the latter work [7], it was found that the membrane stress criterion may become non-conservative for local bending cases of rather thick plates with irregular stiffener arrangements, in which cases the bending stress becomes more important. In addition, this criterion does not account for the possible formation of plastic regions in the stiffeners due to global bending. In such cases, there is need for alternative criteria in order to achieve reliable results.

The main objective of the present study is to investigate the applicability of various strength criteria for use in semi-analytical methods of a kind presented previously by Brubak and Hellesland [7]. The present work represents an extension of that paper and covers ultimate strength predictions of arbitrarily stiffened plates in both local and global bending. The method is not able to predict failure modes due to local buckling of the stiffener. This is not a serious limitation in practical cases as adherence to constructional design provisions in relevant design codes (e.g., Eurocode 3 [8]) prevent premature local stiffener buckling.

2. Plate definition

A structure such as a ship hull or an offshore installation may be built up by stiffened plates with various geometries. A typical

* Corresponding author. Tel.: +47 22 85 59 90; fax: +47 22 85 43 49.

E-mail address: lbrubak@math.uio.no (L. Brubak).

stiffened plate is enclosed by strong longitudinal and transverse girders. In some cases, the stiffener arrangement can be irregular, for instance in the bow and the stern of a ship, or in stinger decks.

In order to model such cases, the plate in Brubak and Helleland [7] shown in Fig. 1(a) is considered. The plate is subjected to a linear varying in-plane compression or tension stress and an in-plane shear stress. A plate edge or a part of a plate edge may be simply supported, or by introducing rotational springs, clamped or partially clamped. The edges are free to move in the in-plane directions, but forced to remain straight. In the figure, only one stiffener is shown, but the number of stiffeners and stiffener inclinations can be arbitrarily chosen. In addition, the stiffeners may be sniped or end-loaded (continuous). The cross section profile of the stiffeners can be symmetric about the middle plane of the plate, or eccentric, as illustrated in Fig. 1(b) and (c) for a flat bar and T-stiffener, respectively.

3. Summary of theory

The load–deflection curve is traced using the elastic, large deflection analysis method presented in Brubak and Helleland [7]. A short review of the main aspects of the background theory is given below.

The material is assumed to be linearly elastic with Young's modulus E and Poisson's ratio ν . Internal axial stresses (σ_x, σ_y) and strains (ϵ_x, ϵ_y) are defined positive in tension, i.e., opposite to the definition of the applied normal stresses at the edges in Fig. 1(a). Positive definition of shear stresses (τ_{xy}) is the same as of S_{xy} in the figure.

The classical large deflection theory [9] is used (large rotations, but small in-plane strains). The membrane components of the in-plane axial strain (ϵ) and shear strain (γ) are in that theory defined by [10]

$$\epsilon_x^m = u_{,x} + \frac{1}{2}W_{,x}^2 + w_{0,x}w_{,x} \quad (1)$$

$$\epsilon_y^m = v_{,y} + \frac{1}{2}W_{,y}^2 + w_{0,y}w_{,y} \quad (2)$$

$$\gamma_{xy}^m = u_{,y} + v_{,x} + W_{,x}W_{,y} + w_{0,x}w_{,y} + w_{0,y}w_{,x} \quad (3)$$

for a plate with an initial out-of-plane imperfection w_0 and additional out-of-plane displacement w . Here, u and v are the displacements of the middle plane of the plate in the x - and y -directions, respectively. The conventional "comma" notation $w_{,xy}$ for $\partial^2 w / \partial x \partial y$, etc., is adopted. The theory implies Kirchhoff's two classical thin plate assumptions that (1) normals to the middle plane remain normal to the deflected middle plane, and (2) normal stresses in the transverse direction are negligible.

The out-of-plane equilibrium is satisfied using the principle of stationary potential energy (Rayleigh–Ritz method) on an

incremental form (rate form). The assumed displacement field and initial imperfection field are defined by

$$w(x, y) = \sum_{i=1}^M \sum_{j=1}^N a_{ij} \sin\left(\frac{\pi i x}{L}\right) \sin\left(\frac{\pi j y}{b}\right) \quad (4)$$

$$w_0(x, y) = \sum_{i=1}^M \sum_{j=1}^N b_{ij} \sin\left(\frac{\pi i x}{L}\right) \sin\left(\frac{\pi j y}{b}\right) \quad (5)$$

where a_{ij} and b_{ij} are amplitudes. The incremental form of the stationary potential energy principle, $\delta \dot{II} = 0$, where II is the total potential energy, leads to $M \times N$ linear equations in $M \times N + 1$ unknowns. A dot above a symbol (\dot{II} , etc.) means differentiation with respect to an arc length parameter η , which can be considered a pseudo-time. The additional equation required is obtained by relating the arc length increment parameter $\Delta \eta$ to a load increment $\Delta \lambda$ and an increment Δa_{ij} in displacement amplitudes. The final set of $M \times N + 1$ equations can be written as

$$\frac{\partial \dot{II}}{\partial a_{fg}} = K_{fgpq} \dot{a}_{pq} + G_{fg} \dot{\lambda} = 0 \quad (6)$$

$$\dot{\lambda}^2 + \sum_{i=1}^M \sum_{j=1}^N \frac{\dot{a}_{ij}^2}{t^2} = 1 \quad (7)$$

where λ is a load parameter, K_{fgpq} is a generalised, incremental (tangential) stiffness matrix, $-G_{fg} \dot{\lambda}$ is a generalised, incremental load vector.

At a specific state "k" in the propagation process, the displacement rates \dot{a}_{ij} and the load parameter rate $\dot{\lambda}$ can be determined from Eqs. (6) and (7). The solution at state "k + 1" is then obtained from a linear Taylor series expansion as

$$a_{ij}^{k+1} = a_{ij}^k + \dot{a}_{ij}^k \Delta \eta; \quad \lambda^{k+1} = \lambda^k + \dot{\lambda}^k \Delta \eta \quad (8)$$

By using this first order expansion, usually called the Euler or Euler–Cauchy method, the solution propagation continues until a given criterion is reached. The incremental procedure, based on a previous work presented by Steen [11], and the expressions for the total potential energy are given in more detail elsewhere [7,12].

The in-plane equilibrium of the plate is identically satisfied by the use of Airy's stress function $F(x, y)$, defined by $\sigma_x^m = F_{,yy}$, $\sigma_y^m = F_{,xx}$ and $\tau_{xy}^m = -F_{,xy}$, where σ_x^m and σ_y^m are the in-plane axial membrane stresses in the x - and y -directions, respectively, and τ_{xy}^m is the in-plane membrane shear stress. By substituting Airy's stress function and strains from Hooke's law for plane stresses into a strain compatibility equation, obtained by differentiation and combination of Eqs. (1)–(3), the nonlinear plate compatibility

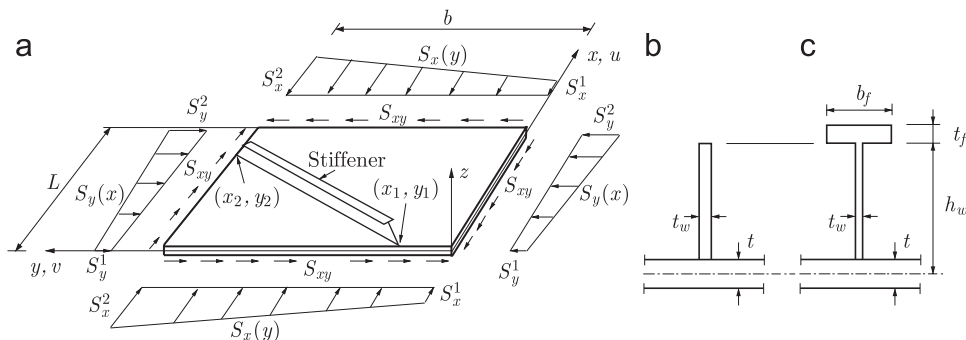

Fig. 1. (a) Stiffened plate subjected to applied in-plane shear stress (S_{xy}) and in-plane, linear varying compression or tension stress (S_x, S_y), and cross section of an eccentric, (b) flat bar and (c) T-stiffener.

equation [10] given by

$$\nabla^4 F = E(w_{,xy}^2 - w_{,xx}w_{,yy} + 2w_{0,xy}w_{,xy} - w_{0,xx}w_{,yy} - w_{0,yy}w_{,xx}) \tag{9}$$

is obtained. A solution of Eq. (9), similar to one proposed by Levy [13] for perfect plates, is assumed. It can be written as

$$F(x, y) = F^L + F^{NL} \tag{10}$$

where

$$F^L = -S_x^1 \frac{y^2}{2} - (S_x^1 - S_x^2) \frac{y^3}{6b} - S_y^1 \frac{x^2}{2} - (S_y^1 - S_y^2) \frac{x^2}{6L} - S_{xy}xy \tag{11}$$

$$F^{NL} = \sum_{i=0}^{2M} \sum_{j=0}^{2N} f_{ij} \cos\left(\frac{i\pi}{L}x\right) \cos\left(\frac{j\pi}{b}y\right) \tag{12}$$

where the coefficients f_{ij} can be found in the literature [7,12]. The linear term F^L and the nonlinear term F^{NL} represent the initial stresses and the redistribution of the plate stresses due to the displacements (w, w_0), respectively.

For the plate stresses, both F^L and F^{NL} are included, and the stiffener stresses are expressed by the plate stresses at the intersection. However, in the strain energy of the stiffeners, the nonlinear term F^{NL} is neglected, but asymmetric effects of eccentric stiffeners are included. This simplified stiffener modelling approach is computationally very efficient. The results presented in the consecutive sections would not be significantly affected if also the nonlinear terms due to plate stress redistribution had been included in the stiffener strain energy. For a detailed discussion of these aspects, reference is made to Brubak and Helleland [7].

4. Strength criteria

In preliminary strength analyses carried out in conjunction with another study [7], the authors found that predicted strengths using the von Mises' yield criterion for the membrane stresses can be non-conservative in cases where the bending stresses are important. In particular, this was found to be the case for (1) stiffened plates in global bending, and (2) irregularly stiffened, thick plates in local bending. In the former case, formation of plasticity in the stiffeners may occur due to global bending. This cannot be accounted for in a criterion that does not include bending stresses and results in a plate model that is too stiff. In the latter case, the non-conservative predictions indicate that the bending stresses at critical parts are important for the ultimate strength.

These two cases demonstrate that there is a need to establish more reliable strength criteria for general cases. Alternative criteria are considered below. It is convenient to present separately criteria for the plate and for the stiffeners. A final criterion for general stiffened plates may consist of a combination of a plate and a stiffener criterion.

4.1. Plate criteria

The criteria considered are all expressed in terms of the yield stress f_Y and the conventional equivalent plate stress given by

$$\sigma_e = \sqrt{\sigma_x^2 + \sigma_y^2 - \sigma_x\sigma_y + 3\tau_{xy}^2} \tag{13}$$

where each stress component is a sum of a membrane “ m ” and a bending “ b ” component:

$$\sigma = \sigma^m + \sigma^b(z); \quad \tau = \tau^m + \tau^b(z) \tag{14}$$

In order to model collapse, strength criteria can be applied at critical points of the plate. The location of these critical points is dependent on the load case. For predominantly lateral pressure, these points can be located in interior plate fields where yielded regions are developed due to large bending stresses. In such cases, bending stresses must be included in the strength criteria. This load case is not studied here, and the strength criteria presented below are only verified for plates without lateral pressure loads.

For plates with predominantly in-plane loads, membrane stresses are redistributed due to out-of-plane displacements from the interior of the plate to the parts of the plate with the largest stiffness. These parts are at the edges and, in addition, at the stiffeners in local bending cases, and it is these parts that are critical for the ultimate strength. When the capacity of these parts are exhausted, no more stresses can be redistributed, and additional in-plane loading cannot be applied without causing collapse.

In some cases, the exact location of the critical points are known and in other cases these points must be found as a part of the analysis procedure. Typical cases for plates subjected to in-plane axial stresses, but no shear, are:

- unstiffened plates as illustrated in Fig. 2(b) where it is necessary to check three possible locations of critical points;
- regularly stiffened plates with four possible check-locations of critical points in the plate, as illustrated in Fig. 2(a) and
- irregularly stiffened plates in which case the critical points are located along the edges and the stiffeners, but where the exact location is not known beforehand.

Unlike in the two first cases, it is necessary to search for the critical points in general cases with irregular stiffeners, etc., and a search procedure is a part of the analysis. It must be noted that such searching is time consuming, and in this respect, the present model can be optimised.

The proposed strength criteria for the plate are given below. All but the first criterion are related to stresses in the critical parts for a plate with in-plane loads.

(P1) “No yield criterion” at any surface point:

$$\sigma_e(z = t/2) = f_Y$$

This criterion is defined by first yield in the extreme fibres of any point in the entire plate, and may also be applied to plates with lateral pressure. Since yielding will give permanent deformations in the structure, this may be a sound design criterion in practise when combined with a similar criterion for the stiffeners. However, in the context of ultimate strength predictions, this is normally too conservative and therefore no results with criterion (P1) are presented.

(P2) “Quarter point criterion” in critical parts:

$$\sigma_e(z = 3t/8) = f_Y$$

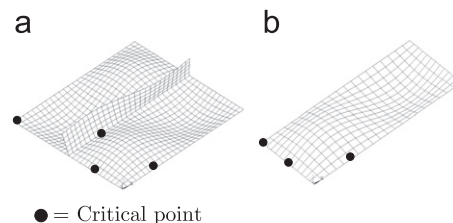

Fig. 2. Critical points in the plate for (a) a regularly stiffened plate and (b) an unstiffened plate.

This strength criterion, defined by first yield at the quarter point of the plate thickness in critical parts of the plate, has been considered in order to account for some bending stresses, typical for irregularly stiffened, thick plates. This criterion allows for the formation of some plasticity. Such criteria applied also at other z -values have been considered. However, it was found that criterion (P2) gave the better agreement with finite element analysis in most cases.

(P3) “Membrane stress criterion” in critical parts:

$$\sigma_e^m = \sigma_e(z = 0) = f_Y$$

This strength criterion, defined by first yield at the midplane ($z = 0$) in critical parts, is the von Mises’ yield criterion for the membrane stress mentioned previously. This criterion allows for more plasticity than criterion (P2). Results using this criterion are included to demonstrate that it is a non-conservative approach in cases where the bending stresses in the plate are important.

(P4) “Interaction curve criterion” in critical parts:

$$\left(\frac{\sigma_e^m}{f_Y}\right)^2 + \frac{1}{\alpha} \frac{\sigma_{e,max}^b}{f_Y} = 1 \quad \text{where } \alpha = 1.5$$

This strength criterion is applied to critical parts of the plate, and is defined by the interaction between the membrane stress and the maximum equivalent bending stress $\sigma_{e,max}^b$ in the outer plate fibres ($z = t/2$).

Strength criterion (P4) is based on an analogy to the plastic capacity interaction formula for a rectangular cross section with area A , given by

$$\left(\frac{N}{N_p}\right)^2 + \frac{M}{M_p} = 1 \tag{15}$$

Here, N and M are the applied axial load and moment, respectively, as defined in Fig. 3 along with a typical plastic stress distribution, and $N_p (= f_Y A)$ and M_p are the corresponding plastic section capacities when they are acting alone. Substituting $N = \sigma_e^m A$, $N_p = f_Y A$, $M = \sigma_{e,max}^b W$ and $M_p = f_Y Z$, where W and Z are the elastic and plastic section modulus, respectively, Eq. (15) yields the criterion (P4). For a rectangular cross section, the shape factor becomes $\alpha = Z/W = 1.5$.

Similar interaction formulas for the cross section capacity have also been considered, e.g., by using other shape factor values or by calculating the equivalent membrane stress as the equivalent stress of the total stresses at the outer fibres minus the equivalent bending stress $\sigma_{e,max}^b$. However, analyses showed that criterion (P4) gives better results than these alternative approaches.

4.2. Stiffener criteria

For global bending cases, it may be important to use a stiffener criterion in addition to the plate strength criterion, because the

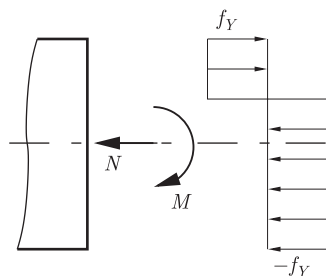

Fig. 3. Plastic stress distribution for a cross section subjected to an axial load and a moment.

stiffener stress may be critical for the ultimate strength in such cases. The criteria for the stiffeners will be given in terms of the stiffener stress σ_s , which is a sum of a membrane stress component expressed by the redistributed plate membrane stresses and a bending stress component expressed by the curvature in the stiffener direction [7].

A prerequisite for reliable results by the present model is that no failure due to local stiffener buckling occurs. Premature local stiffener buckling can be prevented by using constructional design provisions, as discussed later, in combination with the presented stiffener criteria. Two possible criteria for the stiffeners, S1 and S2, are proposed and given below:

(S1) “No stiffener yield criterion”:

$$\sigma_{s,max} = f_Y$$

This criterion is defined by first yield in tension or compression at the location of the maximum stiffener stress $\sigma_{s,max}$. Stiffeners in compression must be capable of developing first yield in extreme fibres prior to local stiffener buckling. Criterion (S1) may give very conservative ultimate strength predictions for global bending cases, and therefore no results using criterion (S1) are included in the present paper. As mentioned before, this criterion in combination with plate criterion (P1) may a sound criterion in practical design in order to prevent permanent deformations.

(S2) “Stiffener reduction criterion”: Cross sections along the total stiffener length are reduced with the yielded area in which $\sigma_s \geq f_Y$ (Fig. 4) in the most strained cross section of the stiffener.

This is a stiffener reduction criterion and accounts for the plasticity in stiffeners either in tension or compression in a simplified manner. Stiffeners in compression must be able to develop plastic deformations prior to local stiffener buckling. Fig. 4 illustrates how the cross section of a stiffener is reduced due to large stresses from global bending about the axis of bending at $z = z_c$. All the cross sections along the entire stiffener length are reduced with an equal portion as at the cross section with the largest stresses. This is a conservative choice.

Due to the reduced stiffener area, the axis of bending (at $z = z_c$) and the moment of inertia will change. In the same manner as in Brubak and Hellesland [7], the axis of bending z_c and the moment of inertia are calculated for a cross section consisting of the stiffener and an effective plate width b_e as illustrated in the figure. A value $b_e = 30t$ is used in [7] and in the present computations.

In criterion (S2), the reduced stiffener cross sections at a specific state “ k ” in the propagation process, are used in the stiffness computation. In this manner, the progression of plasticity is calculated a posteriori. This is a non-conservative approach, but not significantly so for small incremental step sizes. In addition, this is partly or totally compensated for by the conservative

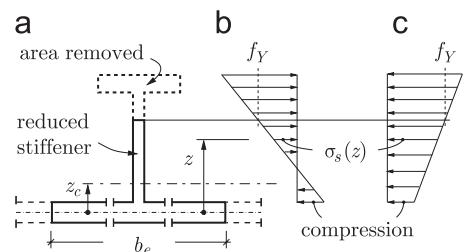

Fig. 4. Stiffener cross section with the maximum elastic stress: (a) reduced stiffener area due to yielding, and possible stress distribution due to global bending in (b) positive z -direction and (c) negative z -direction.

assumption that all the cross sections along the entire stiffener length are equally reduced. Convergence tests, similar to a test presented in Brubak and Helleland [7], showed that the incremental step size used in the analysis presented in the consecutive sections ($\Delta\eta = 0.01$), gives satisfactory results.

The stress distributions shown in Fig. 4(b) and (c) are typical for global bending in the positive and negative z -direction, respectively. The former one is usually the most critical for sniped stiffeners because the out-of-plane displacements usually are largest in the stiffener direction due to the eccentric loading (at the plate edges only). The latter distribution is usually critical for continuous stiffeners in global bending. In order to achieve the most conservative results, analysis for both global bending in the positive and negative z -direction may be necessary, and with the imperfection added in the corresponding direction. For both stress distributions in the figure, the stiffener criteria (S1) and (S2) can be used, independent of whether a stiffener is end-loaded or not.

As mentioned above, for a stiffener subjected to compression, premature local stiffener buckling must be prevented. This is a prerequisite for criteria (S1) and (S2). Without more refined buckling analysis of the stiffeners, this can be done by applying constructional design provisions such as for instance given in Eurocode 3 [8]. There, provisions are given for three different cross section classes, Classes 1, 2 and 3. Class 1 cross sections are able to develop plastic hinges without reduction of the resistance, Class 2 can develop plastic deformations, but have limited rotation capacity and Class 3 cross sections are capable of developing first yield at extreme fibres.

In conjunction with the stiffener reduction criterion (S2), the requirements for Class 2 are probably acceptable. These requirements are expressed in terms of the cross section dimensions. For instance, compression parts of T-stiffeners with a Class 2 cross section, subjected to a constant stress according to Eurocode 3, must satisfy

$$c_w/t_w \leq 38\sqrt{235/f_Y}; \quad c_f/t_f \leq 10\sqrt{235/f_Y} \quad (16)$$

where c_w is the free or unsupported web height (e.g., the clear distance between the welds at the ends of the web) and c_f is the unsupported flange outstand. More slender stiffeners are allowed for stiffeners subjected to both membrane and bending stress.

Without a more refined analysis, it may be necessary to use stiffener criterion (P1) instead of (P2) for stiffeners which satisfy the cross section requirements for Class 3, but not for Class 2. This is not necessary for the stiffened plates presented in the consecutive sections as the stiffener cross sections satisfy Eq. (16).

5. Analysis premises

The present criteria for strength predictions are incorporated into a Fortran computer program based on a semi-analytical method presented previously by Brubak and Helleland [7]. For a variety of plate and stiffener dimensions, ultimate strength limit (USL) predictions by this program have been compared with fully nonlinear, finite element analyses by ANSYS [14] using Shell93 elements. The comparisons include simply supported plates with both regular and irregular stiffener arrangements with eccentric, sniped stiffeners. In USL predictions by ANSYS, both geometric and material nonlinearities are considered.

For verification purposes, the imperfection shape is taken equal to the first buckling mode of the stiffened plate, with a maximum value $w_{0,\max} = 5$ mm in the stiffener direction. For both the present model and the ANSYS model, the elastic material properties used are $E = 208,000$ MPa and $\nu = 0.3$, and the yield strength is $f_Y = 235$ MPa. In the fully nonlinear ANSYS analyses, a

bilinear stress–strain relationship is used that is defined by the material properties above, and additionally by a hardening modulus $E_T = 1000$ MPa.

The number of degrees of freedom is about 20,000 in a typical USL analysis by ANSYS, which is believed to ensure satisfactory results. In comparison, the displacement field in the present model is defined with 15 terms in each direction (225 degrees of freedom), which generally provides sufficient numerical accuracy. A rather small rate parameter $\Delta\eta = 0.01$ is used, and it is discussed in more detail elsewhere [7], along with load application details and convergence tests for decreasing step size.

6. Local and global bending—single, regular stiffener

A stiffener arrangement is considered to be regular if the stiffeners are oriented parallel to the edges and, in the case of simply supported plates, are equally distributed over the entire plate, i.e., with the same spacing between each stiffener. A variety of such stiffened plates subjected to in-plane loading have been analysed.

Although it is most common, and economical, in practical design to proportion the stiffeners with a sufficiently large stiffness so as to prevent a global bending mode, it is still of interest also to be able to compute the global bending behaviour and strength with satisfactory accuracy. Therefore, both global and local bending cases are considered for selected plates.

First, the quadrated plates labelled 1 and 2 in Table 1 are considered. The plates are simply supported, and each have a single, eccentric sniped stiffener located at $y = b/2$. The stiffener of the first plate is a flat bar and of the second a T-bar. By varying the stiffener height h_w , both global and local bending cases can be obtained, as illustrated by Fig. 5(a) and (b), respectively. Typical USL results and elastic buckling stress limits (ESL) are shown in Fig. 6. The ranges with global and local buckling are indicated in the figure.

The USL model predictions with strength criterion (P4) in combination with the stiffener reduction criterion (S2) (“criterion (P4) + (S2)”, thick, solid line) are in close agreement with the ANSYS results, both in the local and the global bending range. In the global range, the ANSYS analyses have shown that there are significant plastic regions in the stiffener due to large tensile

Table 1
Dimensions (mm) of plates with regular, eccentric stiffeners of variable height h_w

	L	b	t	t_w	b_f	t_f	s
Plate 1	2000	2000	20	12	0	0	1
Plate 2	2000	2000	20	12	$0.75h_w$	20	1
Plate 3	2000	6000	20	12	0	0	5
Plate 4	2000	6000	20	12	$0.75h_w$	20	5

s = number of stiffeners.

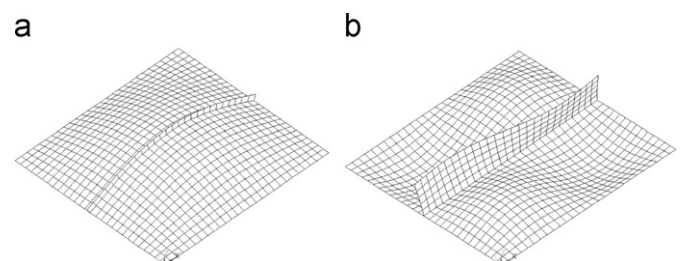

Fig. 5. (a) Global and (b) local bending mode of Plate 1 computed by ANSYS.

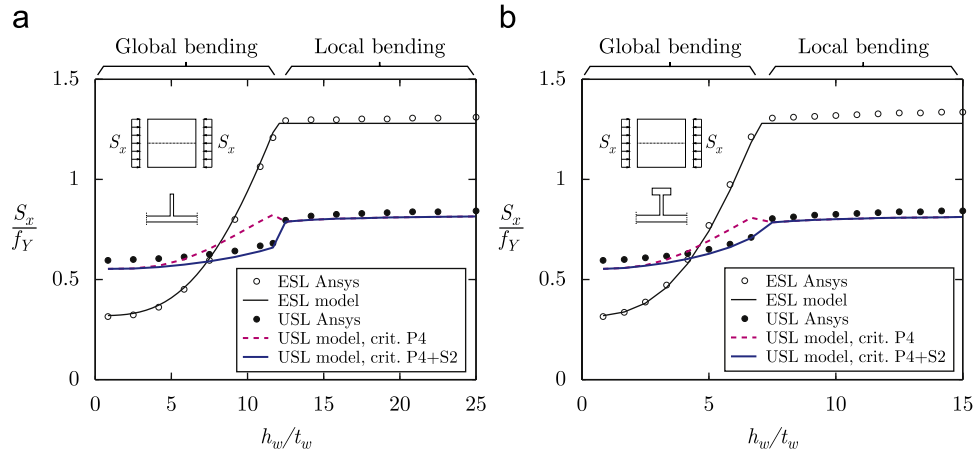

Fig. 6. Uniaxial USL and ESL predictions versus stiffener height h_w of quadratic plates with a single regular stiffener: (a) flat bar stiffener (Plate 1) and (b) T-stiffener (Plate 2).

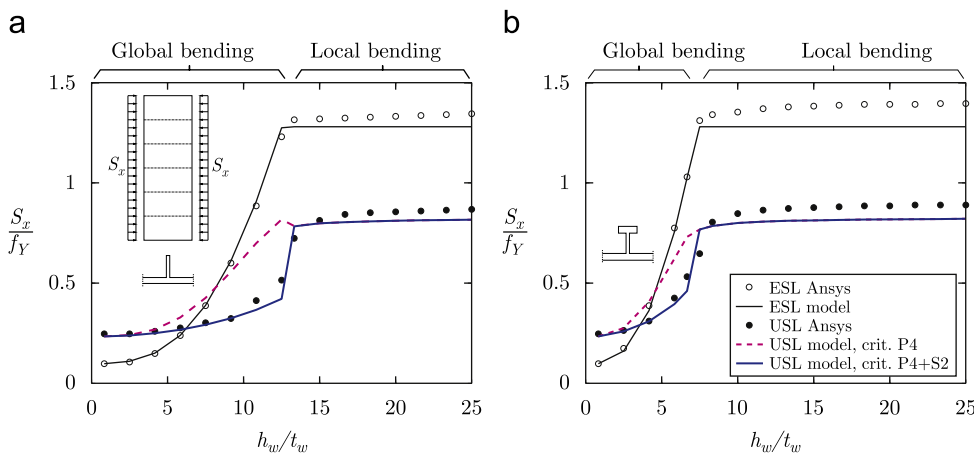

Fig. 7. Uniaxial USL and ESL predictions versus stiffener height h_w of plates with five identical regular stiffeners: (a) flat bar stiffeners (Plate 3) and (b) T-stiffeners (Plate 4).

stresses from global bending. This plasticity is clearly reflected quite well by the additional stiffener criterion (S2), which accounts for the progressing plasticity in a simplified manner by reducing the stiffness (removing area) of the stiffener.

By excluding criterion (S2), plasticity in the stiffener will not be accounted for, and the resulting model will be too stiff. This is clearly demonstrated in the figure by the USL results obtained with criterion (P4) alone (dashed line), which are seen to significantly overestimate the strength in the global range.

The bending modes for the plates, shown in Fig. 5(a) and (b), are typical for simply supported plates with regular stiffeners. Along the edges, the bending stresses are zero because the plates are simply supported. In addition, in the local bending range, the bending stresses (or curvature) are small in each direction (x and y) along the stiffener. For such cases, with small (or zero) bending stresses at the locations where the strength criteria are applied (“critical parts”), the difference in results using strength criterion (P2), (P3) or (P4) is small. Consequently, results with criterion (P2) and (P3) are not shown.

The elastic buckling stress limits (ESL), or first eigenvalues, computed by present model (Fig. 6; thin, solid curve) and by ANSYS (open dots), can be seen to be in very good agreement for both plates. The minor discrepancy in the local

bending range is believed to be primarily due to the effect of neglecting the torsional stiffener stiffness in the present model. The discrepancy is, as expected, somewhat greater for the T-stiffener.

With increasing stiffener stiffness, the buckling mode changes from a fully global mode to an almost fully local mode at the threshold value, at which the rather flat plateau begins. It can also be seen in the figure that the USL predictions are larger than the ESL predictions in the first half of the global bending range. In this range, the plates are slender and have reserve strengths beyond the elastic buckling load.

7. Local and global bending—multiple, regular stiffeners

Similar results to those above are shown in Fig. 7 for plate 3 and plate 4 (Table 1). Each plate is simply supported and is provided with five identical and regularly spaced, eccentric sniped stiffeners.

As for the quadratic plate, USL model predictions with criterion (P4) combined with criterion (S2) (“criteria (P4) + (S2)”, thick, solid line in the figure) are in good agreement with the corresponding USL results by ANSYS. By omitting the stiffness reduction criterion (S2), the resulting USL model predictions with

strength criterion (P4) alone (dashed line), become even more non-conservative in the global bending range than was the case for the quadratic plates above (Fig. 6). This is due to the greater number of stiffeners.

Also the ESL model results are still in good agreement with the ESL results by ANSYS. The difference between these results in the local bending range, as well as between the USL results in that range, are somewhat greater than before. This was to be expected, since the effect of neglecting the torsional stiffness of the stiffeners increases with increasing number of stiffeners.

8. Local bending—irregular, inclined stiffeners

In practise, it is failure associated with local bending modes that is most common since properly designed stiffeners generally

Table 2
Dimensions (mm) of plates with two inclined, eccentric T-stiffeners

	<i>L</i>	<i>b</i>	<i>t</i>	<i>h_w</i>	<i>t_w</i>	<i>b_f</i>	<i>t_f</i>
Plate 5	1200	2400	22	211	12	150	22
Plate 6	1600	2400	22	211	12	150	22
Plate 7	1000	3000	16	208	8	100	16
Plate 8	1000	3000	10	205	8	100	10

prevent global bending modes. For this reason, the suitability of the various criteria for strength prediction have been studied more closely for local bending cases of in-plane loaded plates with small and large slenderness values.

Typical cases studied are the plates defined by the dimensions given in Table 2 and by the rather irregular stiffener arrangement illustrated in Fig. 8(a). The stiffener arrangements, consisting of eccentric T-stiffeners (Fig. 1(b)), are chosen solely in order to provide severe test cases for the different criteria.

Bending shapes calculated by the present model and by ANSYS are found to be very similar. As expected with the chosen stiffeners, bending modes are found to be local for all the plates. Since the bending modes are local, the stiffener stiffness reduction criterion (S2) does not have any influence on the computed results.

USL and ESL predictions by the present model and by ANSYS are presented in Figs. 8 and 9 by interaction curves in the applied in-plane stress space *S_x-S_y*, for various combinations of in-plane compression or tension. No external shear stress is applied. Also included in the figures are the von Mises' yield ellipse, which represents the material as such. The ESL results are included in order to indicate to what extent the plates may be considered thick or slender (thin). The greater the ESL value is for a given load combination, the smaller is the slenderness.

USL model predictions obtained with the membrane stress criterion (P3) (dash-dot lines in the figures) can be seen to be

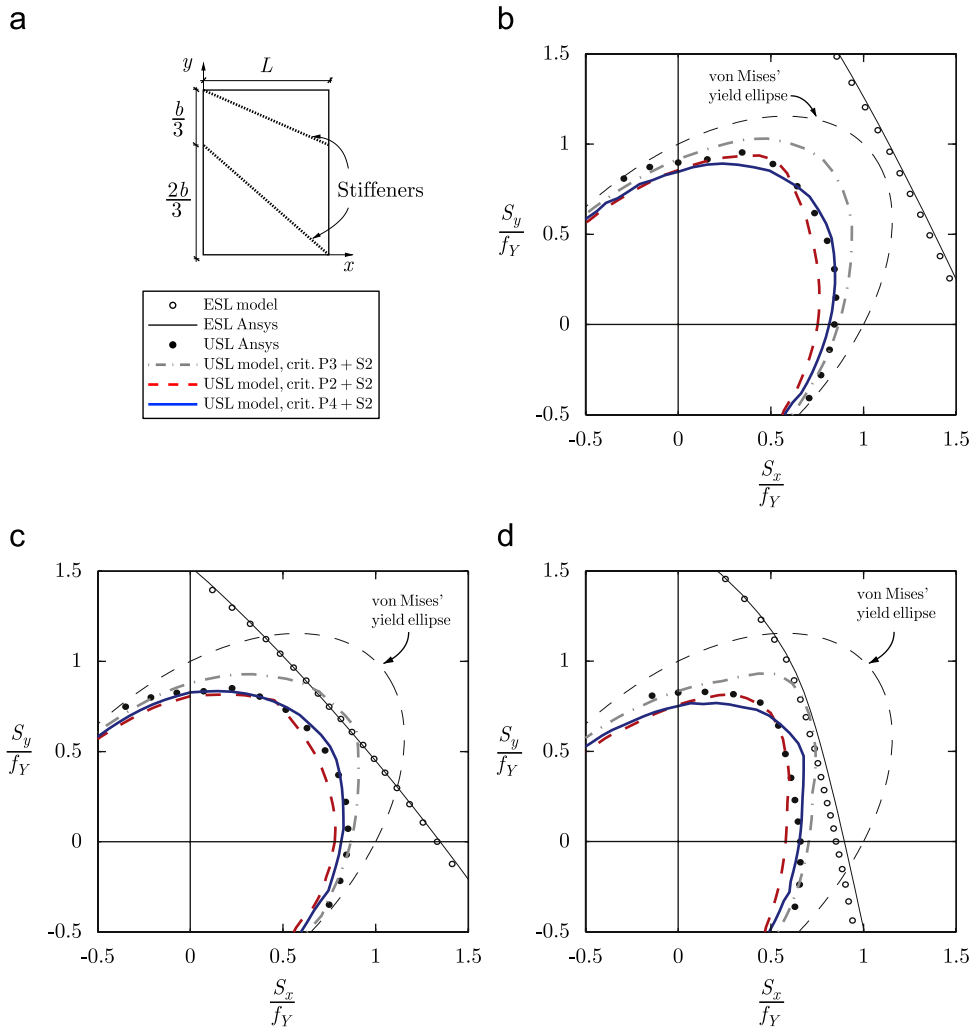

Fig. 8. Interaction curves in the stress space *S_x-S_y* for plates no. 5, 6 and 7, with two eccentric, inclined T-stiffeners.

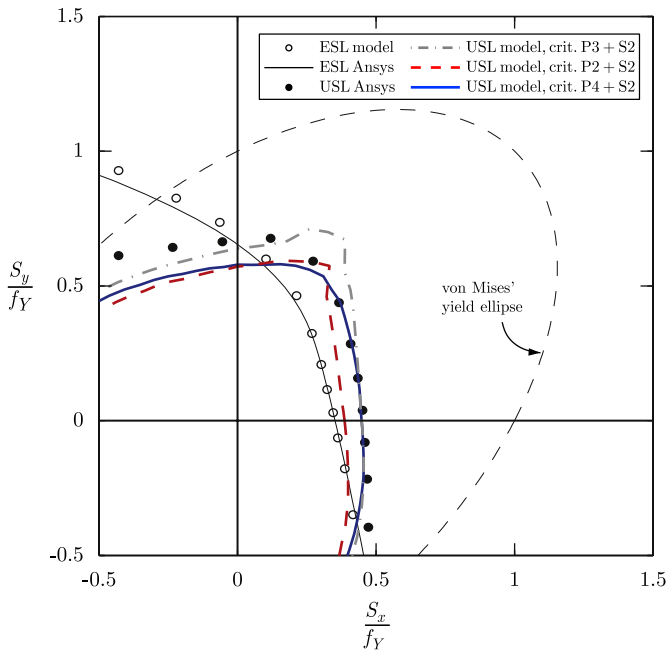

Fig. 9. Interaction curves in the stress space S_x – S_y for the slender plate no. 8 with two eccentric, inclined T-stiffeners (Fig. 8(a)).

quite non-conservative compared to the ANSYS results (filled dots) for the three Plates 5, 6 and 7 in Fig. 8. These plates have small to intermediate slenderness values and can be considered relatively thick to moderately thick plates.

For Plate 8, Fig. 9, USL predictions with the membrane stress criterion (P3) is better than found above. This plate has a considerable reserve strength, typical for slender plates, beyond the elastic buckling load (ESL curves) for major biaxial compression combinations. Consequently, the neglect of bending stresses in the criterion would seem not to be so important for thin, slender plates. However, predictions are still non-conservative in one region near $S_x = 0.5S_y$. This could partly be alleviated by considering several imperfection shapes, and selecting the most unfavourable one. This is discussed more elsewhere [7] for this particular case.

In the figures, USL model predictions with the quarter point criterion (P2) (dashed lines) are seen to be in generally good agreement with the ANSYS results for all the plates studied, although somewhat conservative for some load combinations. The agreement is significantly better than that obtained with the membrane stress criterion (P3). This indicates the importance of including bending stresses in the strength criterion (P2) in the general case.

Overall, it would seem from the figures that the best USL model predictions are obtained with the interaction curve criterion (P4) (thick, solid lines). Like criterion (P2), (P4) also reflects the effect of bending stresses. Compared to predictions by criterion (P4), criterion (P2) results in predictions that are slightly more conservative for most, but not all, axial load combinations.

9. Local bending—irregular, parallel stiffeners

Similar interaction results (in-plane, no shear) to those presented above for the plates with inclined stiffeners, are given in Fig. 10 for an irregular stiffener arrangement defined by the insert in the figure. The plate ($L/b/t = 1000/2000/10$ mm) is simply supported and provided with two eccentric T-bar stiffeners

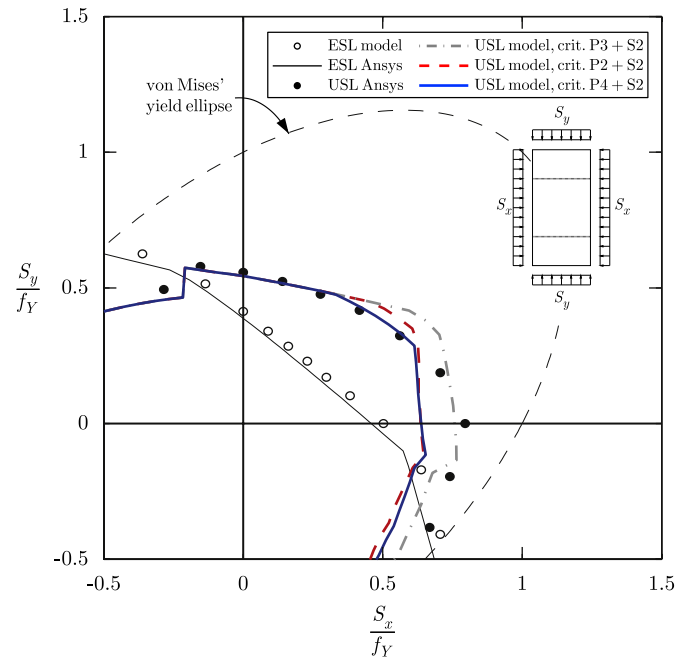

Fig. 10. Interaction curves in the stress space S_x – S_y for a slender plate with two parallel T-stiffeners with unequal spacing.

($h_w/t_w/b_f/t_f = 295/10/150/10$ mm) parallel to the edges, and located at $y = b/4$ and $y = 3b/4$, respectively.

Bending modes calculated by the present model and by ANSYS are still similar for all load combinations, and, also in this case, they are found to be local modes due to the chosen, strong stiffeners. As mentioned before, the stiffener stiffness reduction criterion (S2) does not affect predicted strengths in such cases.

This plate is even more slender than Plate 8 above. It has, as seen, considerable reserve strength above the elastic buckling load (ESL) for most load combinations. As for Plate 8, USL model predictions computed with the membrane stress criterion (P3) compare well with the ANSYS results, except for some biaxial load cases, in which the model predictions become somewhat non-conservative.

USL predictions with the quarter point criterion (P2) and the interaction curve criterion (P4) are seen to be almost identical. They are in excellent agreement with, or somewhat conservative compared to, ANSYS results. The conservativeness is largest when the dominant applied stress component (S_x in this case) is acting in the same direction as the stiffeners.

The abrupt change in the USL interaction curves obtained by the present model, in the second and fourth quadrant, is due to a corresponding abrupt change in the imperfection shape (taken equal to the ESL eigenmode). The change in eigenmode is reflected by a marked change in the slope of the ESL curve in the figure. For the plates with the inclined stiffeners, the buckling mode changes more gradually in the applied stress space S_x – S_y .

Thicker plates with the same stiffener arrangement as the present slender plate, have also been analysed. The conclusions of that study are the same found above for thicker plates with inclined stiffeners (criterion (P3) is non-conservative; criteria (P2) and (P4) give generally good predictions).

10. Summary of proposed criteria and recommendations

Four criteria related to the plate ((P1), (P2), (P3), (P4)) and two criteria related to the stiffener ((S1), (S2)) have been defined.

In the general case, a complete criterion is defined by a combination of one plate criterion and one stiffener criterion. The stiffener criteria (S1) and (S2) affect results only in global bending cases.

In practical design cases in which it may be called for to limit development of plastic regions, the combined criterion that prevents yield at any location in the plate or stiffener ((P1) + (S1)) may be applied. However, such a criterion is not of particular interest when the aim is to predict the USL as correctly as possible with a semi-analytical method. Therefore, a combination of some of the other criteria, which allow for some formation of plasticity, must be used.

For stiffeners with compression in the extreme fibres, premature local stiffener buckling must be prevented as a prerequisite for using the stiffener criteria (S1) and (S2). This can be done by applying constructional design provisions such as for instance given in codes [8], if not more refined buckling analysis of the stiffeners is carried out.

Conclusions and recommendations of this study can be summarised as follows:

- (1) The results confirm a previous observation [7] that the membrane stress criterion (P3) (yield at the midplane) may become significantly non-conservative in general cases in which the effect of bending stresses become important. Typically, this has been found to be case for plates in global bending and for irregularly stiffened, thick plates in local bending. Also, the membrane stress criterion can be non-conservative for plates subjected to a lateral loading [12]. Consequently, this criterion is not recommended in the general case.
- (2) The importance of the bending stresses in the plate on the ultimate strength of irregularly stiffened, thick plates in local bending is accounted for in the quarter point criterion (P2) and the interaction curve criterion (P4). These criteria combined with the stiffener reduction criterion, both provide predictions that are in good agreement with results from fully non-linear ANSYS analyses. Criterion (P2) is generally, although not always, more conservative than (P4).
- (3) By including the stiffener reduction criterion (S2) in an analysis, the formation of plasticity in the stiffener can be modelled. This is documented by comparisons with finite element analyses (ANSYS) for a wide variety of plate and stiffener dimensions.
- (4) The combined criterion (P4) + (S2) (or (P4) + (S1)) is overall found to provide best predictions and is recommended on the basis of the wide variety of cases studied, including local and global bending of arbitrarily stiffened plates with small or large slenderness values.
- (5) For regularly stiffened, simply supported plates subjected to in-plane loads, the bending stresses at the critical parts are normally small (or zero). Then it makes little difference for the ultimate strength which of the criteria (P2), (P3) or (P4) that are used in the computation.
- (6) For predominantly lateral pressure loads, a strength criterion with bending stresses included, similar to criterion (P2) or

(P4), may have to be applied also at the interior plate fields. This loading is not considered in the present paper.

11. Concluding remarks

Various strength criteria that may be used in semi-analytical methods for ultimate strength prediction of arbitrarily stiffened plates in local and global bending have been studied. Results are compared with fully nonlinear finite element analyses for a variety of plate dimensions and stiffeners with regular and irregular arrangements. Good agreement is obtained with a combination of a plate and a stiffener criterion, in particular for an interaction curve criterion in combination with a stiffener reduction criterion. The method is computationally very efficient, and it is suitable for incorporation into computerised analysis and design codes.

Acknowledgements

The authors would like to thank dr.scient. Eivind Steen and dr.ing. Eirik Byklum, both at Det Norske Veritas, Norway, for their general interest and encouragement throughout the study.

References

- [1] prEN 1993-1-5. Eurocode 3: design of steel structures. Part 1.5: plated structural elements. Brussels: CEN, European Committee for Standardisation; 2005.
- [2] Det Norske Veritas. DNV rules for classification of ships. Høvik, Norway: Det Norske Veritas; 2002.
- [3] Paik JK, Lee MS. A Semi-analytical method for the elastic-plastic large deflection analysis of stiffened panels under combined biaxial compression/tension, biaxial in-plate bending, edge shear, and lateral pressure loads. *Thin-Walled Struct* 2005;43(3):375–410.
- [4] Byklum E. Ultimate strength analysis of stiffened steel and aluminium panels using semi-analytical methods. Dr. Ing. thesis, Norwegian University of Science and Technology, Trondheim, Norway; 2002.
- [5] Brubak L, Helleland J, Steen E. Semi-analytical buckling strength analysis of plates with arbitrary stiffener arrangements. *J Constr Steel Res* 2007;63(4):532–43.
- [6] Brubak L, Helleland J. Approximate buckling strength analysis of arbitrarily stiffened, stepped plates. *Eng Struct* 2007;29(9):2321–33.
- [7] Brubak L, Helleland J. Computational postbuckling and strength analysis of arbitrarily stiffened plates in local and global bending. *Thin-Walled Struct* 2007;45(6):620–33.
- [8] prEN 1993-1-1. Eurocode 3: design of steel structures. Part 1.1: general rules and rules for buildings. Brussels: CEN, European Committee for Standardisation; 2003.
- [9] Bažant ZP, Cedolin L. Stability of structures. Oxford: Oxford University Press; 1991.
- [10] Marguerre K. Zur theorie der gekrümmten platte grosser formänderung. In: Proceedings of the fifth international congress for applied mechanics, 1938. p. 93–101.
- [11] E. Steen, Application of the perturbation method to plate buckling problems. Research Report in Mechanics, No. 98-1, Mechanics Division, Department of Mathematics, University of Oslo, Norway; 1998, 60pp.
- [12] Byklum E, Amdahl J. A simplified method for elastic large deflection analysis of plates and stiffened panels due to local buckling. *Thin-Walled Struct* 2002;40(11):925–53.
- [13] Levy S. Bending of rectangular plates with large deflections, Report 737, NACA; 1942.
- [14] ANSYS Inc. ANSYS Documentation 9.0, Southpointe. Canonsburg, PA; 2004.